

FORD
HIGH
PERFORMANCE



FROM YOUR FORD DEALER

PARTS AND SERVICE MARKETING
FORD DIVISION  MOTOR COMPANY
DEARBORN, MICHIGAN



why high performance?

High performance is not new to the automotive world. It is as old as the industry itself. It began with Henry Ford's famous "999" racing car which established the world's speed record in 1903. There was the Model T hot rod of the 1920's which was a customized version of the 20-horsepower engine of that era. The Model A Ford of 1928 added greatly to the performance image of Ford; however, it was still not adequate to meet the demands of a mass market for higher performance. So, in 1932 Ford developed the V-8 engine which produced speeds that were heretofore unknown in low-priced cars.

Today's high performance comes in different forms and means different things to different people. It's not just high-speed operation. High performance can mean a better ride . . . better handling . . . better economy . . . and, of prime consideration today, increased over-all safety.

How do you obtain "high performance"?

With Ford Motor Company, you can obtain high performance in almost any degree you wish. You can get cars with high performance "built-in." You can tailor your car to meet your own individual requirements and you can achieve it little by little or all at once with high performance components ranging from tachometers to complete engines . . . whether for street use, for drag strip racing or for sustained high speed competitive events.

This reference book is designed to acquaint you with some of the high performance products offered by Ford Motor Company. You can obtain these products, as well as service and other assistance on high performance, by contacting your nearest Ford dealer.

In addition, Ford is unique in offering the services of a Performance Advisor to aid in the selection and application of items that will be compatible with your particular vehicle and your personal driving requirements. He is Akton Olson (Ak) Miller who has had a distinguished career in the performance field.

Ak was a co-founder of the oldest hot rod club in America and was instrumental in the establishment of the Southern California Timing Association. He initiated the first annual Bonneville Speed Trial in 1948 and was also a founder of the National Hot Rod Association and is currently serving as a Vice President.

Therefore we invite you to take advantage of the service offered by this distinguished member of the high performance field. Write to:

AK MILLER

FORD PERFORMANCE ADVISOR
P.O. BOX 627, DEARBORN, MICHIGAN 48121

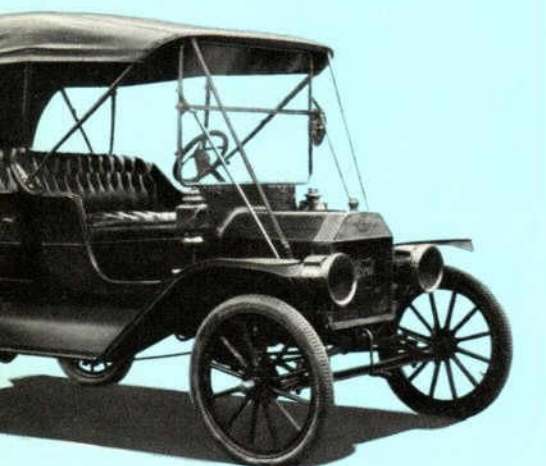

contents

Performance proving	4
The "Indy Car"—Powered by Ford	5
The Ford GT	7
Stock Car and Drag Racing with Ford	9
Holman and Moody and the 427 ... by John Holman	11
The 427 Engine	12
Special features of the 427	13
427 Engine package features	15
427 Engine Specifications	16
Performance adjustments for the 427	17
Cobra—"Powered by Ford" ... by Peter Brock	18
The 289 High Performance Engine	20
Special features of the 289 High Performance Engine	21
289 Engine Specifications	22
Performance adjustments for the 289	23
The 390 Interceptor Engine	24
390 Interceptor Engine Specifications	25
Performance adjustments for the 390	26
The 406 High Performance Engines	27
Put Cobra Venom in Your V-8!	28
Cobra Kits for 221, 260 and 289 engines	30
Combination Engine Performance Kits	30
Cylinder Head and Valve Kit	30
Authentic Cobra Medallions	30
High Performance Cam Kit	31
Distributor Kit	31
Heavy-Duty Clutch Kit	31
Competition Oil Pan	32
Dual Exhaust Kit	32
Scatter Shield Kit	32
Single 4-V Induction Kit	33
Three 2-V Induction Kit	33
Two 4-V Induction Kit	33
Four 2-V Weber Induction Kit	34
Engine Dress-Up Kits	34
Valve Cover Kits	34
Cobra Horsepower Potential	35
Conversion Notes on the 221, 260 and 289 Engines ...	36
Tips and Precautions for All Engines	37
General Modifications Do's and Don'ts ... by Ak Miller	38
Other High Performance Equipment	39
High Performance Kit for 352, 390 and 427 blocks..	39
Engine Dress-Up Kit	39
Tachometers (including Mustang Rally Pac)	40
Lake Pipes	41
Limited Slip Differential	41
Mustang Styled Steel Wheels	41
High Performance Exhaust Manifolds	42
Racing Spark Plugs	42
Solid Core Spark Plug Wires	42
General Parts List for the 427 High Performance Engine	43
General Parts List for the 352, 390 and 406 High	
Performance Engines	49
General Parts List for the 289 High Performance	
Engine	54
Extremely Competitive Event Components—Special	
Order Parts Listing	60
Your "Performance Headquarters"	63

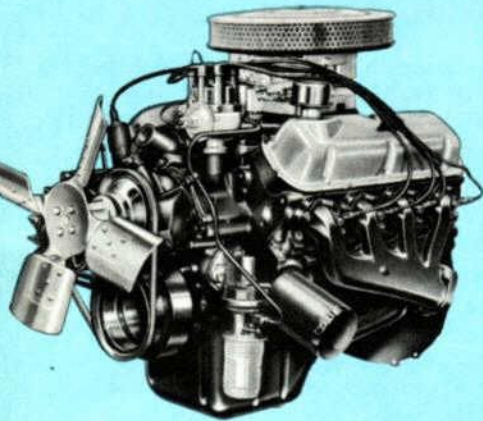
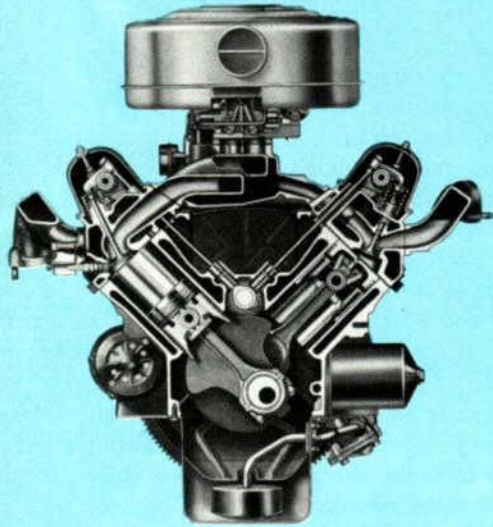
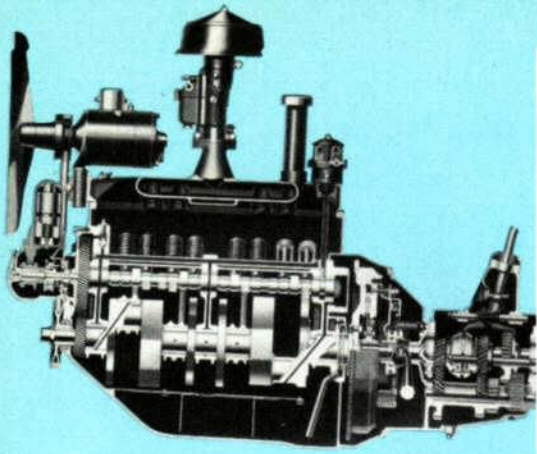



DAYTONA INTERNATIONAL SPEEDWAY



DEARBORN PROVING GROUND



ARIZONA PROVING GROUND



MICHIGAN PROVING GROUND

performance proving...

Daytona, Darlington, Riverside, Charlotte, and Atlanta are all familiar names to every automobile performance enthusiast. On these famous tracks, stock cars are put to extreme tests of power, responsiveness, fuel economy, ease of handling, and roadability. Well-supervised test programs that are in no way competitive or open to the general public are often conducted at these tracks, and, coupled with similar tests at Company proving grounds such as Kingman, Arizona, and Romeo, Michigan, and participation in active racing events, significant changes and improvements have found their way into production cars to increase their durability and improve their quality and safety appointments.

In addition, the actual racing events that are held throughout the country each year attract an estimated 43 million spectators to make competitive automobile events one of today's most popular sports. Of course, proper governing bodies, safety devices, and experienced personnel maintain control over such events.

To the automotive engineers who have observed the event, it is a chance to evaluate products of interest within their engineering area, because a well-supervised competitive high-performance event is actually an accelerated test program. In fact, continuous running for 500 miles or more at speeds up to 160 mph could easily be considered the equivalent of 100,000 miles of average customer use. The speed of stock cars in a race is well above what an average owner could or should expect from his own car in everyday use on modern highways.

For example, the Monte Carlo and Shell "4000" rallies helped give Falcon V-8's sharper steering and tougher front suspension. The Indianapolis "500" proved the tremendous potential of the Fairlane V-8 design and sparked the development of overhead cams and fuel injection. From stock car competition, the big Fords have extracted a new freedom from air drag and a fabulous level of engine performance and durability. Ford-powered Cobras, cast new light on cams and carburetion.



The "Indy Car"—Powered by Ford

The Indianapolis "500" has long been known to automotive engineers for its all-out demands on engines and running gear. The challenge to win in open competition such as this serves to stimulate engineering imagination and ability—it presents unlimited opportunities for engineers to demonstrate their high degree of engineering know-how.

The decision of Ford Motor Company to provide power at Indianapolis in 1963 presented a limited time to attain design and engineering objectives. However, the Advance Engine Department of the Ford Engine and Foundry Division accepted the Indianapolis assignment with enthusiasm in spite of the many technical problems that were anticipated.

The basic "260" V-8 design of the Ford lightweight engine family was selected as the most suited to fulfill the requirements of the Indianapolis race (256.284-cubic-inches, or 4.2 liters). This eliminated the need for the usual preliminary design which precedes construction of a new engine. A slight reduction in displacement of the production "260" design was required; the engine block was cast in aluminum, and some magnesium parts were used to provide less than one-to-one power-to-weight ratio.

Still, as modified, the engine had many features found in everyday automobiles—downdraft carbure-

tion instead of fuel injection . . . push rods and rocker arms instead of a gear train-driven overhead cam actuating mechanism . . . and it used gasoline instead of exotic racing fuels.

To expedite the availability of a body and chassis to contain Ford's new race engine, race cars of proven design were investigated. Among these, the Lotus race cars, as produced by Lotus Cars, Limited of London—cars which had accumulated enviable records in European events—were selected. With some modification, the Lotus body and chassis were considered ideally suited to the grueling test of speedway endurance, and two Ford-powered Lotus cars were entered in the 1963 Indianapolis race of championship cars.

The Ford-powered Lotus cars created a furor of pre-race-day speculation as to their capabilities . . . and when the Indy "500" was over, much that was tradition at the Indianapolis Speedway was changed. For the first time in history, a rear-engine car finished among the winners . . . it made the best time ever recorded for a rear-engine car at Indianapolis . . . it made the fastest time ever for an eight-cylinder car of any design at this famous speedway . . . the two Ford-powered Lotus cars entered were the only gasoline-fueled cars in the 1963 race. It was the first time in twelve years that gasoline had been used at



Indianapolis . . . all Indy winners' speeds previous to 1963 were surpassed by the 2nd place Ford-powered Lotus; and race records were established on the 70th, 80th, and 90th laps. In addition, this car made only one pit stop during the entire 500 miles—other cars made three or four.

The Lotus body is essentially like the fuselage of an airplane—no frame, but with aluminum-tube side rails in a ladder-type construction. The body sheet metal is riveted over the side rails to form a "stressed skin" which becomes the structural support of the vehicle. This is commonly known as "monocoque" construction.

The placement of the driver in the Lotus provides a reclining position for ease of control and reduced driving fatigue—and it also contributes to maintaining the low center of gravity of the car.

For the best possible weight distribution characteristics, the bulk of the fuel is carried in separate, but interconnected, fuel cells at the sides and back of the driver. The cells are "bag-type"—similar to those used in military aircraft, and because of their collapsible

nature, the cells do not require venting. Non-return valves between the cells prevent fuel from surging when the car enters a turn—this feature helped reduce tire wear, in addition to reducing side-sway for better control while cornering at the four 90-degree, 1320-foot turns of Indianapolis. Also, because the turns are all left-hand, the entire chassis of the Lotus was offset two and three-eighths inches left of the centerline of the car's track for improved weight distribution on the turns. The straightaways presented no problem with this arrangement.

With the engine to the rear of the driver, the cockpit control area was much more liveable and less noisy because engine heat and exhaust were carried off to the rear. Other advantages include a 40 per cent (front) and 60 per cent (rear) weight distribution factor with the driver and one-half fuel load aboard. Also, the rear engine drive of the Ford-powered Lotus, transmits its power directly to the rear wheels—there is no drive shaft to set up possible vibrations at extremely high speed.

The Ford engine and the lightweight, aerodynamic design of the Lotus, coupled with the engineering modifications to its body and chassis were, in a great measure, responsible for the unprecedented success at Indianapolis in 1963.

"Indy Cars" in 1964

The 1964 Ford Indianapolis engine developed 425 HP at 8,000 RPM and had a torque peak of 295 foot pounds at 6,400 RPM. The new engine had a double overhead cam configuration and since sufficiently large carburetors were not available, it had a fuel injection system. The basic cylinder block, main bearings, crankshaft, ignition system, alternator and water pump components of the 1963 engine were retained.

"Indy cars" powered by Ford again showed great speed at the "500," and went on to give standout performances in other races in 1964. In August, Parnelli Jones drove a Lotus Ford to victory at Milwaukee in a USAC-sponsored 200-mile race. Two other Ford-powered cars also posted record-breaking qualifying speeds. And on September 27, at Trenton, New Jersey, Parnelli Jones piloted a Lotus to another first-place finish, averaging 96.415 miles per hour for the 200-mile race.

The 1965 Picture

In 1965, Ford engines will be more in evidence than ever in Indianapolis-type cars. At the "500," Colin Chapman is scheduled to be back with two Ford-powered Lotus cars and others are expected to use Ford engines for championship car racing events.

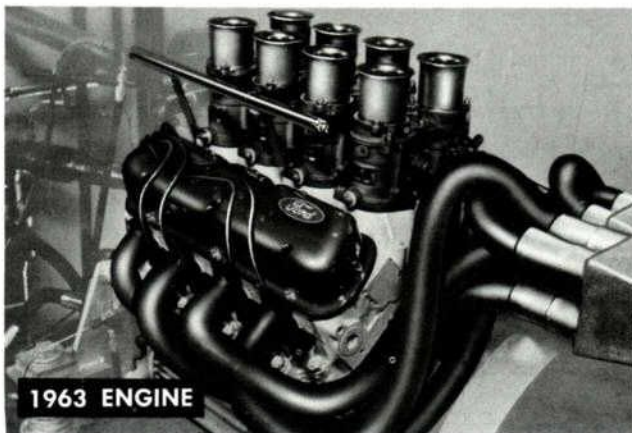

1963 ENGINE

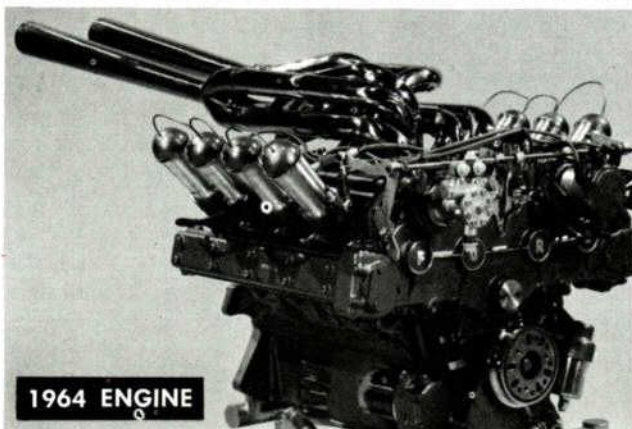

1964 ENGINE

THE FORD

GT

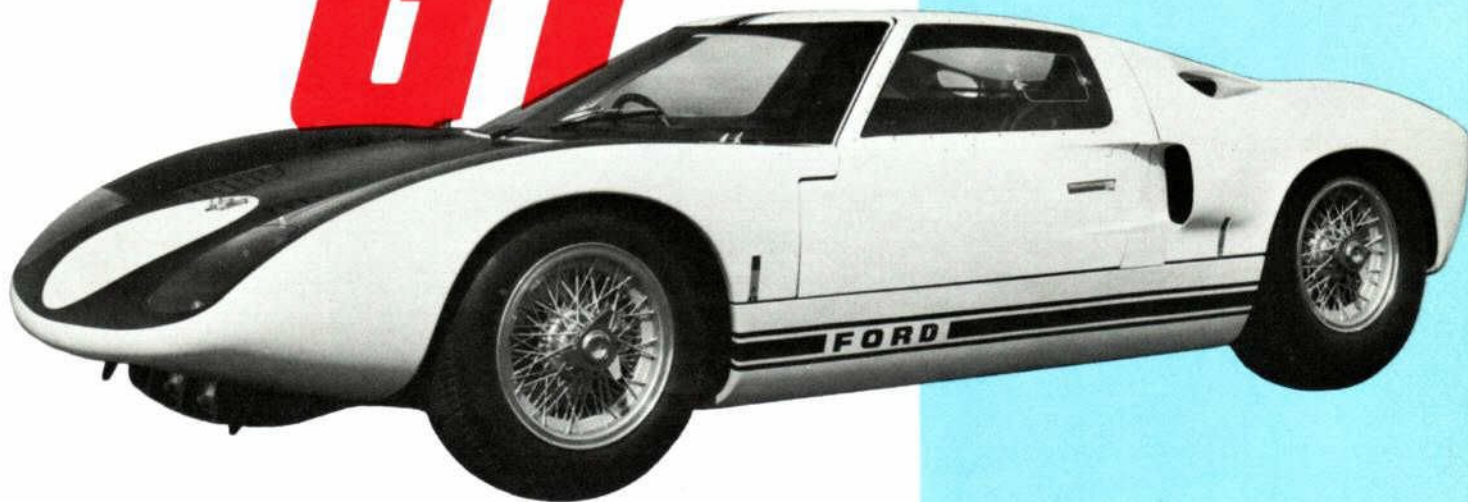

The Ford GT has been well accepted by drivers like Phil Hill, Richie Ginther and Bruce McLaren for its comfortable driver environment and handling ease; not to mention the fact that a GT set a new lap speed record of 131.67 mph at Le Mans in June in only the second time out. The GT is off and running.

In recent years, a new name has entered the American racing picture; the name GT (Grand Touring) describes a field of two-seater cars, driven by a high performance engine, a superb handling car that is usable on public roads and can double as a racing machine.

Racing GT cars has become increasingly popular in America and the term GT is now practically synonymous with sports cars.

In 1963, when Ford extended its participation in competition to include the GT class, it had to come up with a car to fit this new application and this required many unique components.

The conditions encountered by GT vehicles in competition are varied, and generally include all the ills, perils and hazards experienced by normal cars in a lifetime of driving. The course follows main and secondary roads normally used by commercial traffic. There are tight curves that reduce speed to 30 mph, corners that are negotiated at over 100 mph and straightaways that see cars exceed 200 mph.

Ford's main reason for entering GT racing was to simulate functional improvements and innovations applicable to its own production units. The past history of automobile development includes a long line of improvements that can be attributed directly to racing experience, and GT cars have been responsible for many of these contributions. If speeds continue to increase, developments achieved through racing will play an even greater part in the design and construction of future cars that will perform safely in the hands of the public.

For instance, building a car for GT competition involves a great deal of aerodynamic study and the lessons learned in making a GT racing car stable at 200 mph can help in making a family car steady at 80 mph.

Driver environment is another consideration, for GT driving is the ultimate in driving. The driver must be able to devote full physical and mental effort for three and four hours at a time. This calls for snug seating support that will prevent fatigue as well as allowing the driver to change positions now and then to avoid discomfort; thus the ventilated, pneumatic seat back.



Door openings are cut deeply into the roof of the GT, providing stand-up entry and exit and giving the car an unusual gull-like appearance.

INSIDE THE FORD

GT

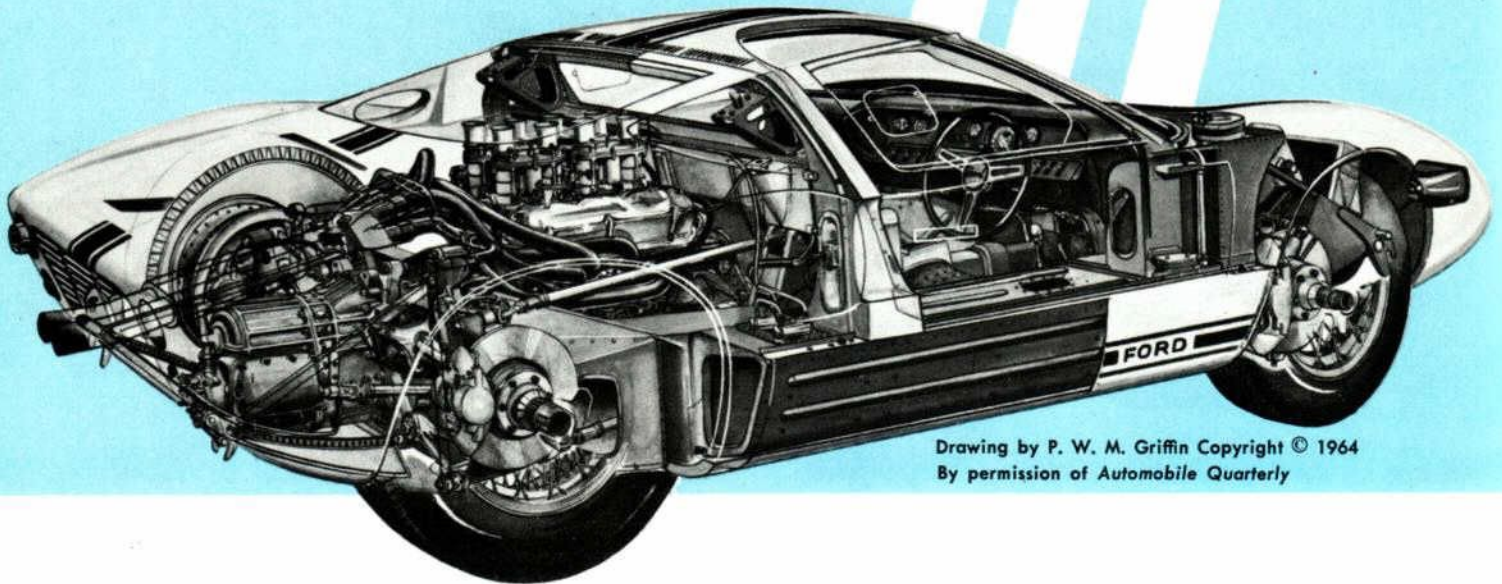

Drawing by P. W. M. Griffin Copyright © 1964
By permission of Automobile Quarterly

The main structure of the Ford GT car is of semi-monocoque steel construction, utilizing the roof skin section as a stressed member. Pontoon sections form the sills, and serve as the basic structural members through the mid-section. Sheet steel members extend fore and aft, providing attachment points for engine and suspension.

Functional aerodynamic form is the basis of the body shape. The body has been styled to low air drag requirements with the combination of small frontal area and low drag coefficient. Wind tunnel tests conducted by Ford at the University of Maryland determined the final body shape.

Among vehicle features are through-flow ventilation, fixed seats with movable controls, ventilated seats with special lumbar support, and aerodynamic cooling system.

The engine for the Ford GT is the 289 High Performance unit, mounted in the midship position forward of the rear axle. It develops 380 (373-383) horsepower on gasoline fed through four dual-throat, 48 mm. Weber downdraft carburetors.

Two neoprene fuel tanks of aircraft fuel-cell design are used and are fitted in the sills on both sides of the vehicle. They provide for a total capacity of 37 gallons. Large-diameter filler necks to both tanks permit a quick-fill operation.

The seats are an integral part of the structure and the clutch, brake and accelerator pedals are mounted as an adjustable unit to accommodate individual drivers. Ventilating seats are provided which can be inflated or deflated to suit the individual.

The exhaust system is of the cross-over tuned type for maximum scavenge effect. Each port exhausts to its own pipe. These pipes then join and form two short exhaust extensions to which silencers are fitted.



Stock Car and Drag Racing with Ford

Competitive stock car events have aided in the development of some of the most important contributions to the safety of modern cars. Four-wheel brakes, pneumatic tires, precise steering geometry, rigid frames and underbody structures, hydraulic shock absorbers—all were developed for and proven in intense competitive events.

Ford's interest in competition stock car racing events increased from 1955 through 1957. During this period, Ford cars ran at the largest and most difficult events in the country, and the grueling tests of the speedway proved to be a prime factor in the research and development of more reliable and safer cars for the general market.

Although the "stock cars" of all manufacturers are modified and highly-tuned versions of cars available through a local dealership, the great majority of the parts in each car is standard equipment. The success or failure of a car in a "stock" event is often dependent on a single item such as a simple bolt, or a piston, or an axle—any one of a thousand things can break down and force the car out of competition. Therefore, through the observance of these events, Ford engineers are assisted in the design and development of new and more durable parts in the new Fords for the general public.

In 1963, Ford entered European competition with specially modified compact Falcon models. This proved to be another display of inherent Ford performance and stamina, when two V-8 powered Falcon Sprints successfully finished the 71-hour, 2,500-mile endurance run in the world-famous Monte Carlo Road Rallye.

Ford returned to Monte Carlo for the 1964 event, finishing first in two classes and second over-all. The driver of one special, rally-modified Falcon Sprint received five trophies for his victories in Class VIII, one of which was the NASCAR trophy for the highest-placed American car in the Rallye.

Just recently, Ford was awarded the NASCAR Manufacturer's Award of Excellence in recognition of Ford's dominance on the ovals in 1964. Competition-equipped Ford Galaxies won 30 Grand National races—more than twice as many as the nearest rival.

At Riverside, in January, 1965, Ford Galaxies got off to another blazing start in stock car competition, sweeping the first four places in the opening event of the 1965 NASCAR Racing Season.

Dan Gurney led the Ford finishers and also set a qualifying record of 103.9 mph. Gurney gave credit for his showing to the 1965 Ford Trailing Arm Coil Spring Suspension and also the improved handling of the 1965 Ford which featured for the first time, Ford's newest 427 CID High Performance engine.

1965 Fords have taken up where the '64's left off. At Riverside, California, in January, 1965, 427-equipped Galaxies finished 1-2-3-4 and were led by Dan Gurney who won the race for an unprecedented third straight time. Gurney's victory clearly established the 1965 Fords as the cars to beat in the 1965 NASCAR season.

What you can get in Ford Stock Cars for 1965



Stock car racing is not limited to the pros. Anyone can experience the thrill of stock car competition with these options in 1965:

- **The 1965 Stock Racing Galaxie.** This car is equipped with heavy-duty suspension components and a full roll bar cage. The engine is a 427 4V with 7,000 RPM's available. For those who like to do their own work, the basic 427 unit is available and the heavy duty suspension components and racing accessories can be purchased separately.
- **High Performance Mustang.** Sedan Racing and Rally enthusiasts will find that the regular production high performance Mustang with handling package, already proven in competition, is just the ticket. With the addition of various Cobra Kit options allowable under SCCA rules, this is a formidable challenger in many amateur events at a price tag that is compatible with its performance potential.
- **Fairlane Challenger 289 High Performance V-8.** Fairlane's top performer in 1965 is the high-winding Challenger 289 4V High Performance V-8. It comes complete with chrome dress-up kit and choice of four-speed manual transmission or a special version of Ford's three-speed automatic.



The NASCAR Manufacturer's Award of Excellence is stock car racing's way of recognizing Ford's dominance on the ovals in 1964. Competition-equipped Ford Galaxies won 30 Grand National races—more than twice as many as the nearest rival.





DRAG RACING

Drag racing, or "How quick can you accelerate for a quarter mile from a standing start," is fast becoming the most popular and widespread performance event in the United States. Not only as a spectator sport but in participation by non-professional drivers, it is reaching fantastic proportions. Drag racing events bring out audiences ranging up to 20,000 persons weekly at an estimated 500 drag strips across the country.

In 1964, Ford entered the drag racing picture with the 427 Fairlane "Thunderbolt." Competition in sanctioned events against cars in its class proved the 427 Fairlane an immediate success. By turning in quarter mile times of less than 12 seconds with top speeds of over 120 mph, many of the country's previously unbeaten super stock drag cars were quickly eliminated

by the new Fairlane. This car was given the 1964 NHRA Manufacturers award.

Ford's Drag Racing Lineup for '65

The Ford offerings for 1965 will make it possible to tailor a drag car for almost any degree of drag racing performance. The selection will range from the top stock class, all the way down to the starter classes of C and D production.

"Do-It-Yourself" Drag Requirements

In addition to the complete vehicles available through Ford dealers, engines and engine components are offered for "do-it-yourself" drag car builders in the form of Cobra kits and 427 engine options.



427-Equipped "Rail Car"

For the first time, Ford is seriously entering AA/Fuel Dragster competition. Connie Kalitta, one of the nation's foremost drag racers, has installed Ford's fabulous 427 single overhead camshaft engine in his new "Bounty Hunter" rail. This supercharged engine, the most powerful V-8 ever used in a dragster, will turn out over 1,200 horsepower. Kalitta believes that a speed of 210 mph is possible with his new Ford-powered entry. In his initial outing with the car at Phoenix, Arizona, Connie became the first man in history to achieve over 200 mph at an AHRA National Championship event.

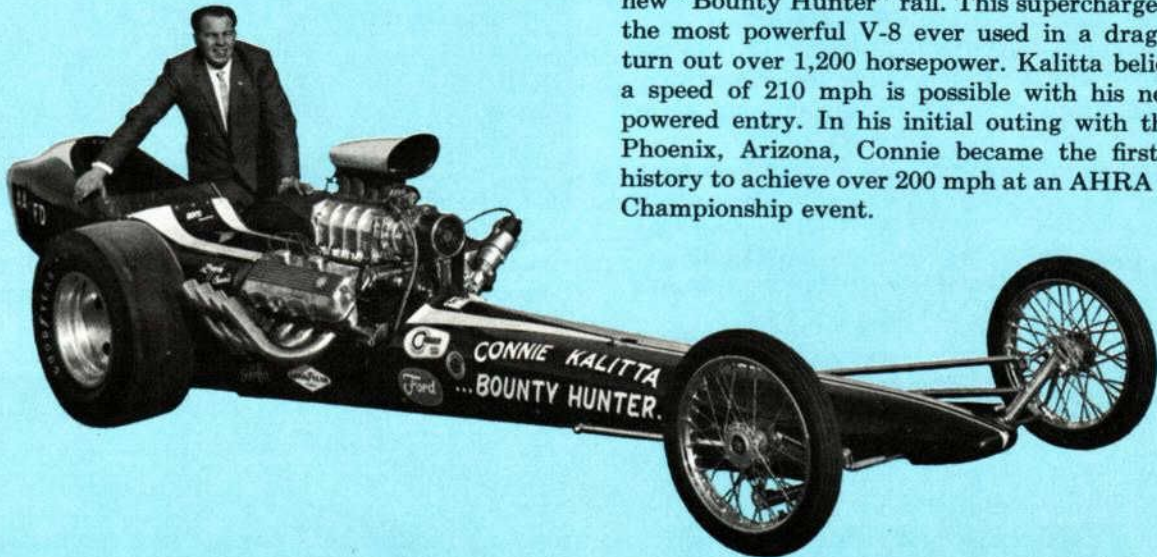

Holman and Moody and the 427

by John Holman

"Why the Ford 427?"

Because our organization makes its livelihood in one of the roughest, toughest, and most demanding sports in the world . . . stock car racing. Unlike many other sports, racing does not make provisions for a "best out of seven games", or an "overtime period", in the event of a tie, to determine a champion. In automobile racing, when the checkered flag is dropped, that's it!

The winning car must (1) go the full distance, and (2) be capable of running up front throughout the entire event. This puts fantastic demands on a power plant in the areas of reliability and performance.

In our long history with racing and high performance vehicles, the Ford 427 has proven that it is better qualified to meet these requirements than any other engine on the market. The Ford

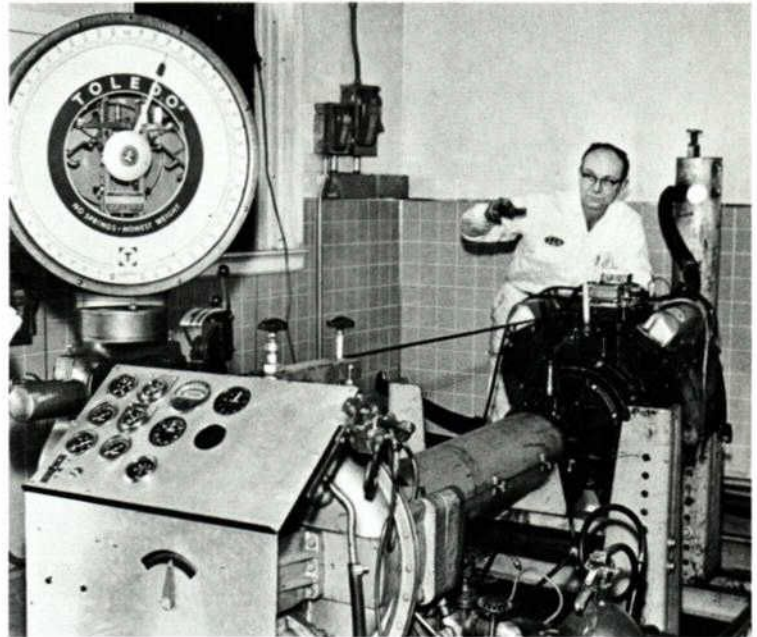

427 production engine, as received in our plant, is totally acceptable for all competitive events in which the average driver might want to participate.

As professionals, our only function is to (1) detect and eliminate any human error that might have occurred in the fabrication and assembly on the component parts, and (2) assemble engines tailored for specific events.

This last operation is called "blue printing", and involves the following:

Select clearances and compression ratio suitable for special application. Cut out under valves until intake has an 0.040 seat; exhaust, 0.060 seat. CC all combustion chambers to 1/10 cubic centimeters of desired volume. Cut both faces of block to 0.001 variation deck clearance from cylinder to cylinder. Hone cylinder walls. Hone and fit piston pins. Hand fit piston rings. Side clearance connecting rods. Clearance crank. Balance rods, pistons, pins, crankshaft damper, flywheel and clutch cover. Re-assemble engine, degree camshaft. Dynotune, checking ignition and carburetion with analysers. Break in on dyno. Spot check bearings and change oil filter after break in.

All of the above are dimensional changes only, and should not be considered as modification of an engine in any way, as all changes are within the original specifications of the engine.

We feel that the current 427 is the finest of a long line of Ford engines with outstanding durability and high performance characteristics.

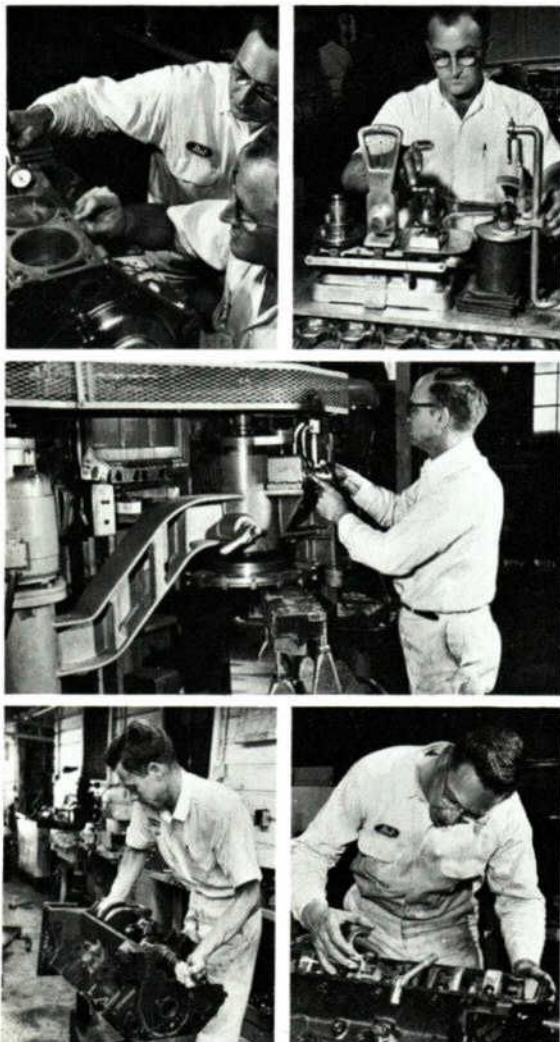



HIGH PERFORMANCE ENGINE

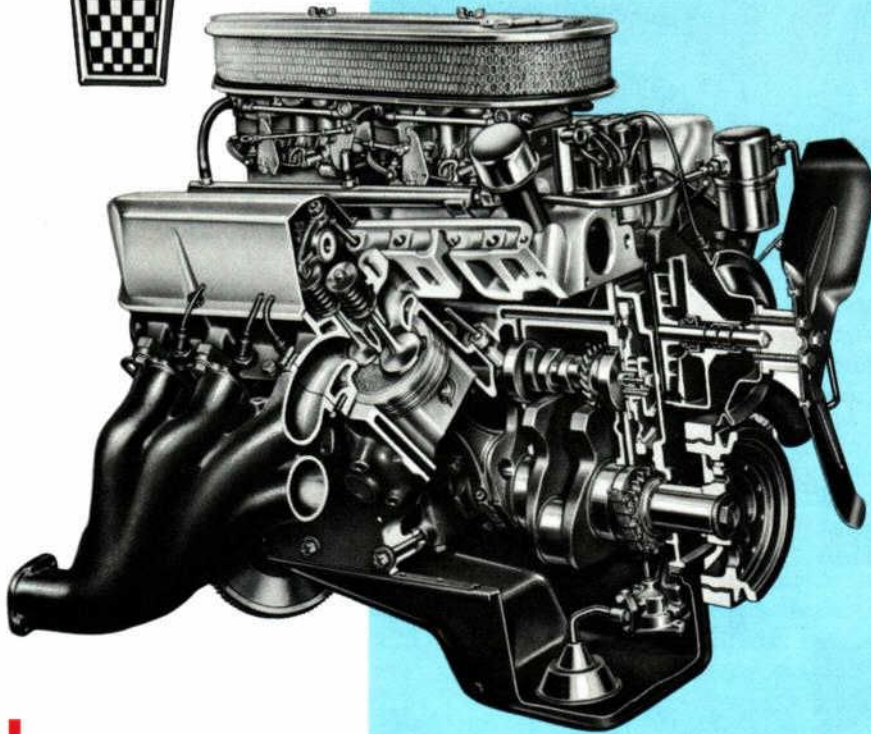

the 427 CID ENGINE

The Ford 427 cubic inch High Performance 8-venturi V-8 engine is the most powerful passenger car engine produced for retail sale by Ford Motor Company. This engine offers many special features which enable it to withstand the stress of high-performance operation and for long life in everyday driving.

The 427 actually had its beginning in 1958 when Ford introduced a new line of engines starting with the 332 cubic inch version. The current series of 427 is a direct outgrowth of this engine. In 1963, Ford marketed a 427 cubic inch high performance engine that scored an unprecedented success in its first outing, winning 1st through 5th positions at the Daytona "500" Grand National stock car race. During the remainder of the 1963 stock car season, Ford cars equipped with the 427 proved their Total Performance capabilities by sweeping the remaining long distance events at Atlanta, Charlotte, Riverside and Darlington. Many of the engine features that made this possible have since been incorporated into the smaller Ford engines.

The current series of high performance engines combines reliability with performance through special cylinder blocks made with larger main bearing webbings. Special attention has also been given to oil supply, oil control and oil pressure. The end result being an engine that provides the buyer with a power plant that idles at a moderate speed and has excellent oil control.

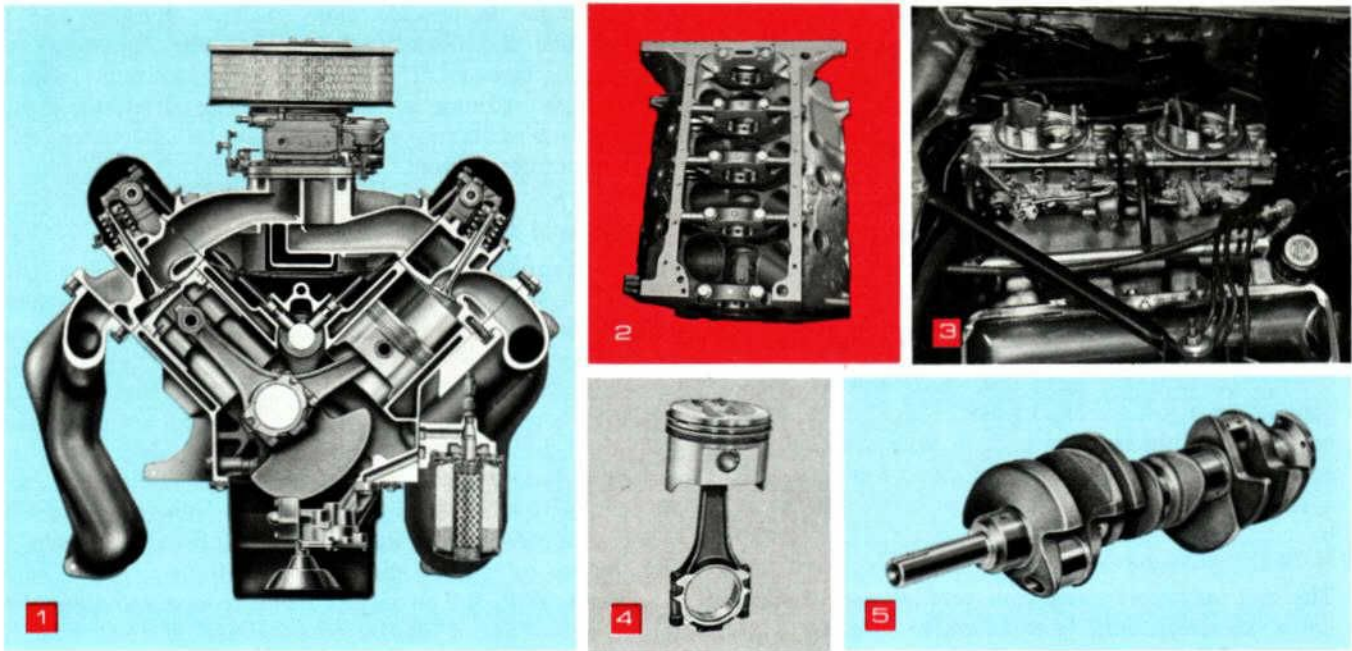

Special Features of the 427

A number of new designs, processes and materials were used in developing the 427 High Performance V-8. These features provide the superior built-in performance and reliability that have been so successfully demonstrated by 427-equipped Fords in sanctioned competitive events.

1 Special Intake System and Valve Train

The 427 engine has an aluminum intake manifold and precision cast-iron cylinder heads incorporating large, unobstructed intake passages to provide a maximum fuel-air charge to each cylinder. The high-performance camshaft has specially contoured cam lobes with high-lift valve openings and greater valve overlap for optimum engine torque characteristics. Positive valve action even at sustained high speeds, is possible with the solid valve lifters used in the 427. The valves are adjustable to provide the "fine tuning" that is so desirable in a high-performance engine.

2 Cross-Bolted Main Bearing Caps

The cross-bolted main bearing caps make possible engine speeds that until now have been impractical in large displacement engines. This new cross bolting method provides precise bearing alignment even under the stress of high engine rpm.

3 Two 4-Venturi Carburetor System

The carburetors used on the 427 High Performance engines employ primary and secondary throttle plates with separate fuel systems. The primary throttle plates function alone when operating below full power. The secondary throttle plates are vacuum controlled and function automatically during rapid acceleration or sustained high-rpm operation.

The primary throttle plates operate in parallel from the accelerator with a progressive linkage system. A

specially designed, low-restriction, racing-type air cleaner with a chrome plated cover is fitted over both carburetors.

4 Impact-Extruded Pistons and Special Connecting Rods

The special connecting rods incorporate scientifically designed reinforcement contours that coincide with the strain pattern developed during high-stress, high-rpm operation. These connecting rods weigh only four per cent more than conventional-design rods, yet have approximately 300 per cent greater fatigue resistance. The cam-ground, impact-extruded pistons have a finer grain structure for high strength and superior resistance to heat and stress. Raised pads on the piston heads can contact the valves in case of valve floating at extremely high rpm.

5 Precision Crankshaft

The precision crankshaft is fully counterweighted and carried in five main bearings. Its short length and the large overlap between main and crankpin journals provide the extra stiffness needed for high-performance durability and long bearing life. All crankshaft oil holes are drilled extra large to provide a generous supply of oil to the bearings under high rpm operation.

The main and connecting rod bearings are of the precision, replaceable, steel-backed insert-type. The bearing material is a copper lead alloy that provides extra load capacity and greater reliability for high-performance usage. The bearings are lead-tin plated for faster break-in.

The crankshaft is electronically balanced to within 1/2 oz/in. before the bearing surfaces are individually gaged to select-fit the bearings. Like all Ford engines, the 427 is balanced as a complete assembly while running on a special balancing machine.

1 Valves for the 427

Exhaust valves are manufactured of 214 N forged steel. For the high-performance application of the 427, the valves feature chrome-plated stems to reduce valve guide wear, and hard silichrome tips on the valve stems assist in retaining valve clearance adjustments. The tops and seating surfaces of the intake valves are aluminized for protection against burning and pitting.

2 Header-Type Exhaust System

Cast iron exhaust manifolds feature individual headers from each cylinder. The headers provide efficient evacuation of the combustion chambers by reducing exhaust back pressure and interaction or pulse between adjoining cylinders. The headers empty into the dual exhaust pipes, providing a complete low-loss exhaust system.

3 High Performance Camshaft

The specially contoured cam profiles permit high-lift valve openings and greater valve overlap for the optimum engine torque characteristics. The camshaft actuates the valves through mechanical valve lifters that have cast-in holes for lightness; helping to provide more positive valve action at all speeds.

4 Alternator Charging System

The high-performance engines are equipped with an

alternator to provide more positive charging and to improve the overall efficiency of the electrical and ignition systems. The use of a simplified, more reliable voltage regulator is possible with the alternator charging system because it requires less voltage control than a generator system.

5 Optional Transistorized Ignition System

For competition use, the optional transistorized ignition system is highly desirable, providing an increase in combustion efficiency through greater spark plug voltage, especially at higher speeds.

In the transistorized ignition system, the current to the distributor breaker points is comparatively low, while the current to the ignition coil is high, due to the fact that the two are fed by separate circuits. In a conventional system, the breaker points and coil are in the same circuit, and the coil primary current is limited by the amount of current the points can withstand. With the stronger current throughout the entire primary circuit in the conventional system, there is greater metal transfer from contact-to-contact which causes pitting and results in a shorter service life for the points.

In addition to providing greater overall efficiency, the optional transistorized ignition system reduces oxidation of the distributor breaker points for longer life, and helps prevent spark plug fouling through the hotter spark.

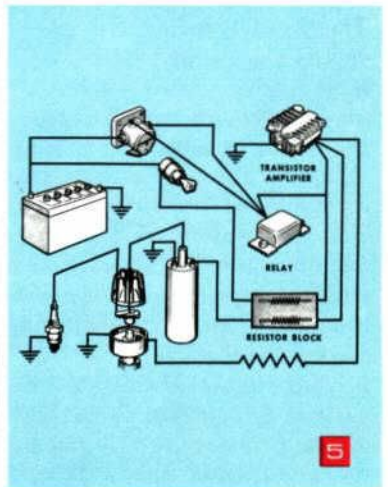
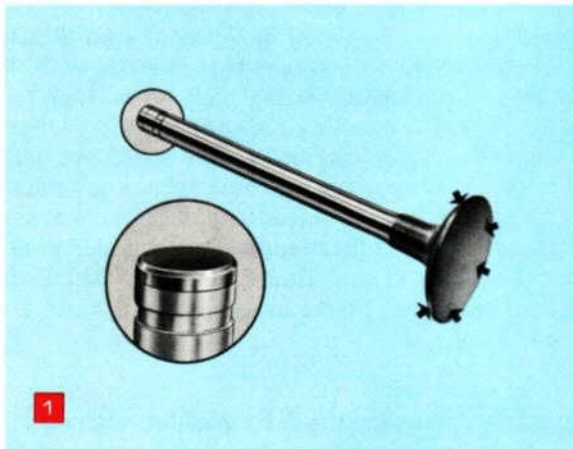

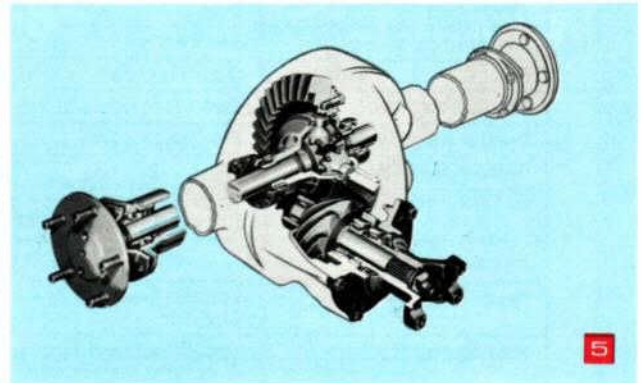
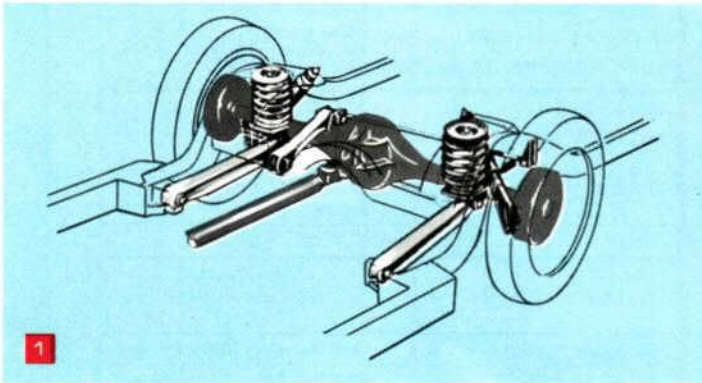
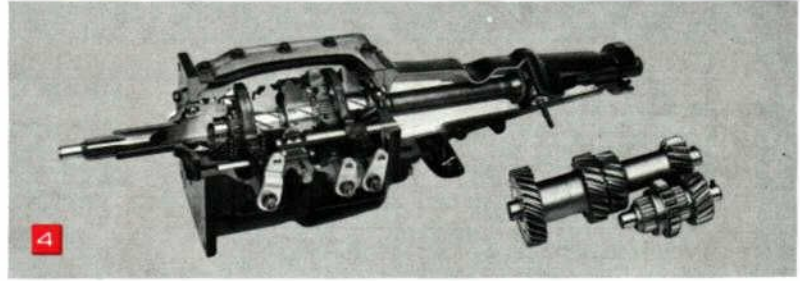
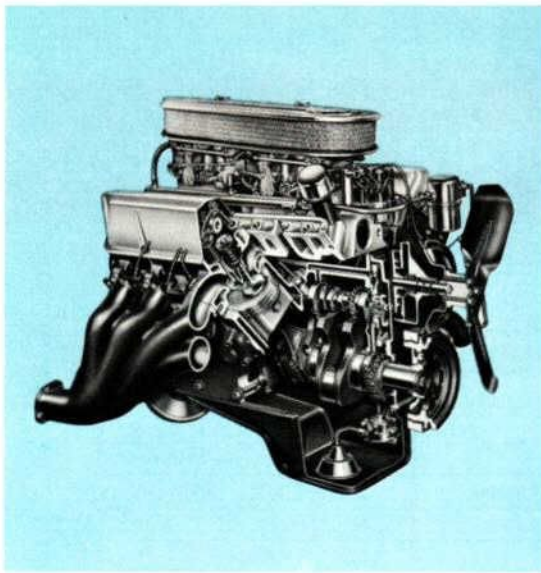

427 Engine Package Features

All Ford vehicles equipped with 427 engines also include certain heavy-duty mandatory options, which are combined with the engine into one high-performance package. This is in the interest of safety and in keeping Ford foremost in satisfying the trend toward Total Performance vehicles.

- 1 THE SUSPENSION . . .** Heavy-duty front and rear springs and shocks contribute to Ford's superb handling on turns and excellent stability with increased safety.
- 2 THE WHEELS AND TIRES . . .** Included are 15 inch wheels for fewer wheel turns per mile and better brake ventilation, and 7.10 x 15 nylon premium tires that resist ply separation and damage from impact.
- 3 THE BRAKES . . .** Molded asbestos linings that are tailored for the best thermal conductivity make the heavy-duty brake assemblies fade-resistant. The large 11 inch brake drums have 381 square inches of swept area, and the brake lining gross area is 234 square inches.
- 4 THE TRANSMISSION . . .** The ultra-flexible, Ford-built 4-speed manual shift transmission used with the

427-cubic inch engine features full synchronization of all forward gears. This engine-transmission combination allows rapid upshifts for lively acceleration and split-second downshifts for maximum performance and control in passing and engine braking.

The gears and bearings in this performance-type transmission are designed for extended operation in any ratio.

- 5 THE REAR AXLE AND DRIVE SHAFT . . .** The Ford rear axle and differential in the performance package features a 9-inch ring gear and a 4-pinion differential. The pinion drive gear is straddle-mounted with two heavy-duty tapered roller bearings ahead of the gear and a straight roller bearing behind. Heavier rear wheel bearings are also used with high performance vehicles.

The three inch driveshaft used with the 427 engine is a one-piece tubular type with a forged steel yoke at either end. Particular care is given to the dynamic balancing of the shaft to provide more vibration-free operation at high rpm.

The front and rear universal joints have low-friction needle bearings for smooth operation and high load carrying ability.



427 High Performance Engine Specifications

GENERAL		EXHAUST VALVES	
Type	8-cylinder 90 degree Vee, Overhead Valve	Material	21-4N Forged Steel with Chrome Plated Stem and Silichrome tip.
Displacement	427 Cubic Inches	Overall Length	5.246"
Bore & Stroke	4.2328" x 3.784"	Overall Head Diameter	1.723"—1.733"
Compression Ratio	11.1:1	Angle of Seat & Face	44°
Brake Horsepower	4V-410 @ 5600 rpm 8V-425 @ 6000 rpm	Lift	0.298" at Valve
Valve Lifters	Solid	Spring Pressure & Length	80-90 lbs. at 1.82" (valve closed) 255-280 lbs. at 1.32" (valve open)
Carburetor	Two 4-venturi	PISTONS	
Fuel	Super Premium	Material	Extruded Aluminum Cam Ground
Exhaust	Dual	Weight	23.31 oz.
Cylinder Block Material	Precision-Cast Iron	PISTON RINGS	
Cylinder Head Material	Precision-Cast Iron	No. 1 Compression	Cast Iron Alloy Chrome Plated
Oil Filter	Rotunda 6000 Mile Type—Part No. C1AZ-6731-A (R1-A)	No. 2 Compression	Cast Iron Alloy Chrome Plated
CRANKSHAFT		No. 3 Oil Control	Multi-Piece—Two Chrome Plated Steel Rails and One Blued Steel Expander
Material	Precision-Molded Alloy Cast Iron	Width—No. 1	0.0774"—0.0781"
Main Bearings (5)	Steel-Back Copper-Lead Alloy Replaceable Inserts	No. 2	0.0930"—0.0940"
Main Bearing Journal Diameter	2.7484"—2.7492"	Gap—Nos. 1 & 2	0.010"—0.020"
Thrust Bearing	No. 3	No. 3	0.015"—0.055"
Crankpin Journal Diameter	2.4380"—2.4388"	PISTON PINS	
CAMSHAFT		Type	Full Floating Tubular
Material	Precision-Molded Special Alloy Iron	Material	SAE 5015 Alloy Steel Heat Treated
Bearings (5)	Steel-Back Babbitt Inserts	Length	3.202"—3.212"
Camshaft Gear Material	Molded Nylon on Aluminum Die Cast	Diameter	0.9750"—0.9753"
VALVE SYSTEM		Bushing	Bronze
Operating Tappet Clearance	0.025 (hot)	CONNECTING RODS	
Intake Valve Opens	0.006 @ 48° BTDC	Material	Forged Steel with Separately Forged Caps
Intake Valve Closes	0.008 @ 96° ABDC	Weight	26.85—27.30 oz.
Duration	324°	Length	6.486"—6.490" Center to Center
Exhaust Valve Opens	0.006 @ 96° BBDC	CONNECTING ROD BEARINGS	
Exhaust Valve Closes	0.008 @ 48° ATDC	Material	Steel-Back Copper-Lead Alloy Inserts
Duration	324°	Overall Length	0.736"—0.746"
Valve Opening	96°	Clearance Limits	0.0013"—0.0032"
INTAKE VALVES			
Material	Special Alloy Valve Steel with Aluminum Coated Head		
Overall Length	5.446"		
Overall Head Diameter	2.022"—2.037"		
Angle of Seat & Face	29°		
Lift	0.500" at valve		
Spring Pressure & Length	80-90 lbs. at 1.82" (valve closed) 255-280 lbs. at 1.32" (valve open)		



Performance Adjustments for the 427 Engine

GENERAL		FUEL SYSTEM	
Firing Order	1-5-4-2-6-3-7-8	Carburetor Part Number	C4AF-9510-BJ primary C4AF-9510-BK secondary, or C4AF-9510-CU primary C4AF-9510-CV secondary
Valve Clearance	0.028 cold—0.025 hot	Main Metering Jet Identification	C4AF-9510-BJ-46F-58F C4AF-9510-CU-71F-74F C4AF-9510-BK-46F-48F C4AF-9510-CV-71F-74F
Cam Lobe Lift (normal)	0.298	Float Setting (dry)	Top of float to be parallel with top of inverted fuel bowl.
Cam Lobe Wear Limit	0.005	(wet)	Fuel level at lower edge of sight plug.
Valve Lift (theoretical zero lash)	0.500	Initial Idle Mixture Setting	1-1½ turns open
Compression pressure (sea level)	160-200 psi	Accelerator Pump Setting	Summer—No. 1 Winter—No. 2
IGNITION SYSTEM		Accelerator Pump Clearance	0.015
Initial Ignition Timing (New Points)	8° BTDC	Thermostatic Spring Identification	58LI
Final Ignition Timing (tune-up)	8° BTDC	Choke Spring Housing Initial Setting	At Index Mark
Distributor Number	C5AZ-12127-EEZ	Fast (cold) Idle Adjustment	1500 rpm
Centrifugal Advance (set test stand to 0 degree at 2500 rpm and 0 in. HG)	rpm	Advance degrees	Maximum (hot) Idle Adjustment
	650	2¼—4	700-800 rpm
	750	4—5½	Fuel Pump Static Pressure
	1000	7¼—8½	4½—6½ psi @ 500 rpm
	1600	9¾—11	
2000	11½—13		
Maximum Advance Limit	16°	TORQUE LIMITS	
Vacuum Advance (set test stand to 9 Degrees at 1000 rpm and 0 in. HG)	rpm	Advance Degress	Vacuum In. HG
	1000	2-5	8
	1000	4-7	10
	1000	5½-8½	14
Maximum Advance Limit	8½°	Intake Manifold	32-35 ft.-lbs.
BREAKER POINTS		Exhaust Manifold	12-18 ft.-lbs.
Arm Spring Tension—std. ignition trans. ignition	27-30 oz. 22-24 oz.	Oil Pan Drain Plug	15-20 ft.-lbs.
Contact Spacing	0.019—0.021	Oil Filter	With oil on gasket surface, hand tighten until gasket contacts adapter face; then tighten ½ turn more.
Dwell Angle at Idle Speed std. ignition combined trans. ignition	30-33° 22-24°	Connecting Rod Retaining Nut	53-58
Standard Spark Plugs Part Number	COAZ-12405-A (BF-32)		
Spark Plug Size	18 MM		
Standard Plug Gap Width	0.028—0.032		
Spark Plug Torque	15-20 lbs./ft.		



FORDS SWEEP OPENING RACE IN 1965 NASCAR SEASON

This final pit stop was the gateway to the checkered flag for Dan Gurney who led a 1-2-3-4 finish of specially prepared and modified Fords to open the 1965 NASCAR racing season at Riverside, Calif., January 17, 1965.

In becoming the first man in auto racing history to win a 500-mile event three consecutive years—each time in a Ford—Gurney bested a field that saw more top drivers choose Ford and Ford-powered cars than ever before.

Gurney established himself early as the man to beat, qualifying at a record 103.9 miles an hour—faster than any type of race car has ever turned the twisty 2.7-mile Riverside road course.

Gurney gave most of the credit for his improved lap times to the 1965 Ford trailing arm coil spring suspension and showed little of the wear that might be expected from the five hour and 41 minute ordeal of braking, shifting and accelerating.

"I never really ran hard," he said afterwards. "It doesn't pay to run your car hard and build up a big lead. A yellow flag will bunch the field and all you've done is punish your car."

His 1965 Ford, Gurney reported, ran beautifully. It was prepared by the Woods brothers of Stuart, Va., and was much faster than the car he drove here a year ago. He was averaging more than 101 miles an hour at the finish.



... powered by **FORD**

... means
powered by
Ford's new
289 CID 271 H.P.
High Performance V-8



by Peter Brock, Shelby American, Inc.

There's no doubt now, among those who know, that the Ford/Cobra sports car is one of the most spectacular automobiles produced during the last decade. And what makes the whole Cobra program so unbelievable is that only three short years ago the Cobra was only an idea! How did such an automobile achieve its present status as a dominating power on the international automotive scene so quickly and successfully? Carroll Shelby!

Carroll Shelby's years of experience have taught him countless lessons in the art of being successful in

motor racing, not the least of which is components that, combined properly, would spell success on the racing circuits of the world.

In planning an investment the magnitude of the Cobra program in 1961, Carroll Shelby, retired international racing star, was free to go to any manufacturer in the world to choose the exact components he felt necessary to build a world beater.

The problem of the right engine for his Cobra sports racing chassis was not a simple one. Several alternatives were available that could do the job as he envisioned it. His experience had proved that five elements are necessary to build a successful sports/racing engine: (1) power, (2) reliability, (3) potential for future development, (4) availability of parts and (5) ease of service.

In the end, after a careful evaluation of powerplants produced in all areas of the world, only one company emerged which satisfied these requirements: the Ford Motor Company.

Once this decision was reached, a new era in sports car racing was born! Shelby had chosen Ford's new "Challenger V-8" engine. At the time this engine was a totally new development from Ford. It was designed in a new high strength thin-wall cast iron process that compared favorably in weight with the then popular American aluminum V-8's.

Exhaustive tests proved not only the power and reliability of the new engine, but also its willingness to accept requirement number 3 (potential for future development) was unbelievable!



It's almost staggering when one realizes that the original 221 CID, rated at 130 H.P., has developed into today's most successful racing engine. Special experimental versions are churning out well over 400 H.P. with complete reliability!

What is it that makes the Ford V-8 so special? Basically it's a combination of the five elements mentioned above mixed with the technical know-how of Ford and Shelby American racing inventiveness. The catalyst for this volatile mixture is something found only around racing—enthusiasm.

As technical know-how and enthusiasm were combined to build successful racing cars, Shelby began the Cobra Kit program, whereby every successful component or innovation developed in his racing program would be made available to Ford performance fans.

In this way thousands of hours of research would be applied successfully for those enthusiasts who wanted and appreciated such equipment.

Carburetion, camshafts, ignition timing, special high performance heads, special clutches, improved bearing material—all the ingredients of success would become available from any Ford dealer.

The Ford/Shelby group testing and evaluating—inventing and refining—finally came up in early 1963 with a combination now famous to all who know high performance equipment: the Cobra 289 CID high performance version of the standard 289 V-8.

This high performance 289 CID is the same basic engine that has powered the Cobra sports roadster for two years and in racing trim has won the GT classification at the 12 hour Grand Prix of Endurance in Sebring, Florida and the grueling 24 hours at Le Mans in France. It has powered the Shelby team Cobras to outright victories by winning the United States Road Racing Championship and also the Manufacturers Championship. The versatility of this amazing engine is quite evident when one also realizes that the Shelby "Dragonsnake" Cobra roadster holds both the NHRA and AHRA national records for "A" production sports cars.

Cobra powered Fairlanes and Falcons have won so many drag racing awards it would literally take pages just to list them.

This is not to say smugly, "The Ford V-8 with 'Cobra Kit' options is the hottest thing going," for that is not the attitude of success. It can, however, be said that at this time the Cobra Kit Ford is the standard in all types of high performance automotive events whether it be drag racing, road racing, international rallies, gymkhanas, or oval track racing. Time will bring many changes and with the present trend the Ford/Shelby American combination will continue to develop new Cobra Kit components that, combined with other Ford equipment, will keep on producing winners.

COMING UP FAST— THE COBRA 427



The Ford-powered Cobra—most successful American sports racing car in history—has undergone a major mechanical transformation to help insure continued success in 1965.

Designated the Cobra 427, the new vehicle is powered by Ford's 427-cubic-inch high performance engine, and features coil-spring suspension front and rear for optimum road holding. Earlier Cobras were powered by the Ford 289-cubic-inch engine and had leaf-spring suspensions.

Although the Cobra 427 chassis is five inches wider in order to accommodate the new engine, the Cobra's distinctive body style is changed only slightly from previous competition models.

Dual four-barrel carburetors will be installed on the street machine and a single four-barrel carburetor will be used on the competition cars. The 427-cubic-

inch Ford engine is a special light-weight version with aluminum cylinder heads and other light alloy components. A Ford transmission, suited to the Ford 427-cubic-inch engine and with close ratios developed especially for the Cobra, is being used. Magnesium wheels will become standard on all of the Cobra 427 models.

The new suspension was developed to minimize lean in the wheels when the body rolls under cornering forces. The suspension is fully adjustable both front and rear to permit the driver to tailor the handling of the car to his preference.

The first 100 Cobra 427 cars will be competition vehicles to meet the demand for the coming racing season, but when the street machine is available later in 1965 it will have all of the mechanical features of the competition version to continue Shelby's objective of building the world's fastest production sports car.



HIGH PERFORMANCE ENGINE

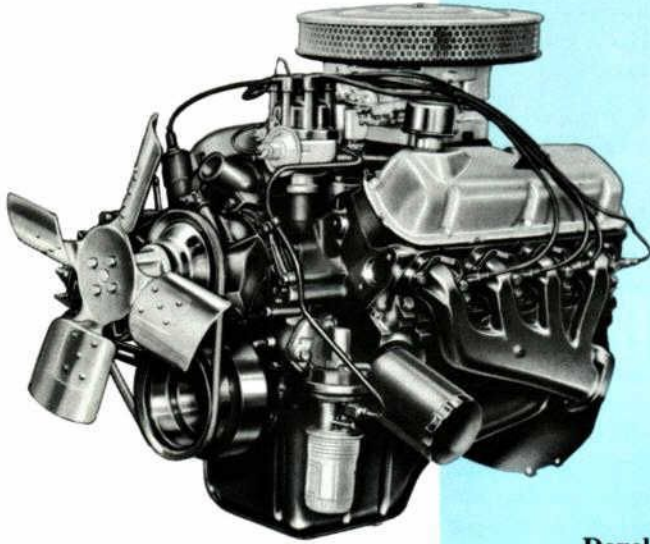

The 289 cubic inch High Performance V-8 engine is an excellent powerplant for Mustang and Fairlane high performance vehicles. If you have a Mustang with this equipment, it is teamed with the Ford ultra-flexible 4-speed manual shift transmission for true sports car feel and performance. If yours is a Fairlane high performance vehicle, you had a choice of either the 4-speed manual transmission or the performance Cruise-O-Matic which provides you the convenience of automatic shifting combined with superb performance.

The high performance output of this engine results from the advanced engineering design coupled with Ford's precision thin-wall casting technique. The high performance 289 C.I.D. develops 271 horsepower at 6000 rpm, with a weight of less than two pounds per horsepower, and delivers 0.95 horsepower per cubic inch of displacement.

Development of the 289 High Performance Engine

The "221" V-8 used in the 1962 Fairlane was the first of the Ford Motor Company's lightweight V-8 engines. It was later supplemented by 260- and 289-cubic-inch versions, forming a lightweight V-8 engine family. With the introduction of the larger lightweight engines, their usage was expanded to include the compact and standard size cars to provide economical, smooth V-8 power.

Due to their lightweight, cast-iron construction, small package size, and the known durability of Ford Motor Company products, many sports car manufacturers became interested in the "260" and "289" V-8 engines during 1962 and 1963. One of the first cars to use Ford Motor Company lightweight V-8's was the Shelby Cobra, which soon became a consistent winner in sports car events. In addition to the Cobra, some of the more famous European manufacturers, such as Lotus, Sunbeam, Lola and Cooper have offered sports models equipped with these lightweight V-8 engines.

A natural addition to the lightweight V-8 engine family, the "289" high performance V-8 introduced sports-type performance to the Fairlane in 1963. This engine incorporates many outstanding features, permitting maximum performance characteristics while still retaining the durability of regular passenger car engines—high compression cylinder heads—11.6:1 maximum ratio . . . connecting rods with 300 per cent greater fatigue life . . . competition-type exhaust headers . . . high-efficiency air cleaner . . . 4-venturi carburetor . . . high-lift camshaft . . . solid valve lifters . . . and a 4-blade aluminum cooling fan.

The 289 High Performance V-8 is a competition engine, capable of racing and winning against many of the best-known sports cars in the world, especially in acceleration events.

The 289 4-V HIGH PERFORMANCE ENGINE

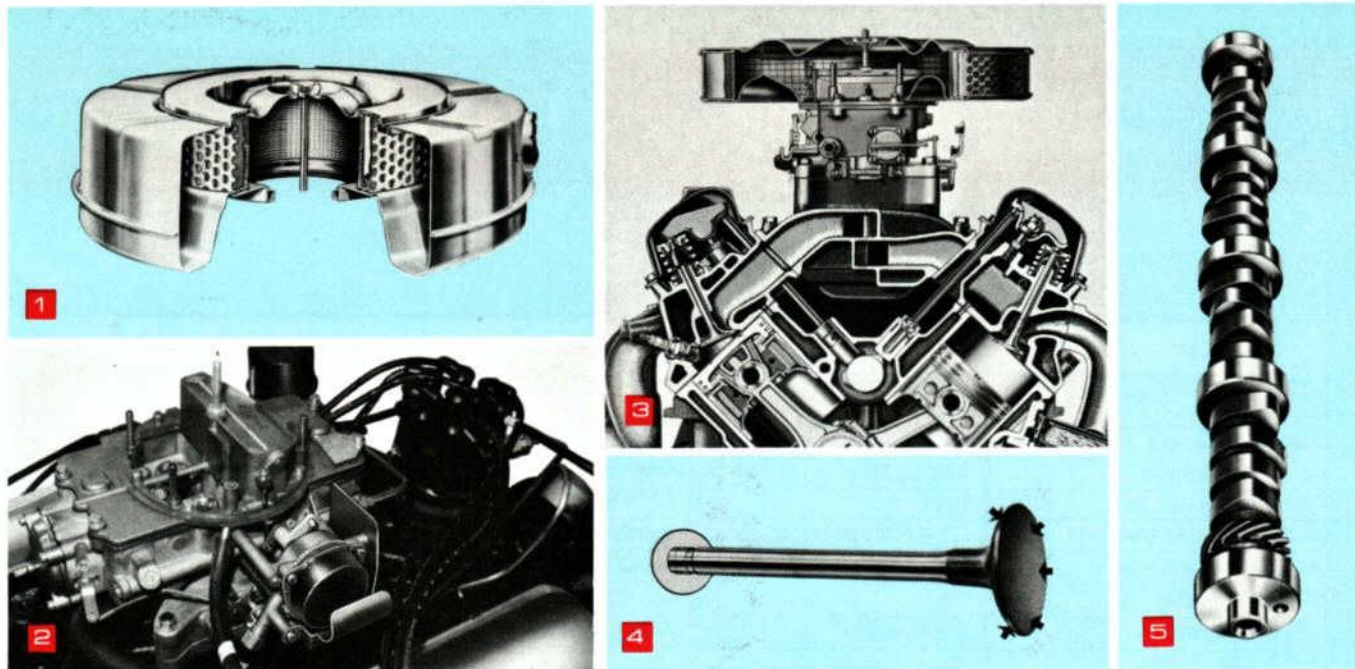

Special Features of the 289 High Performance Engine

1 Racing Type Air Cleaner

Super-Filter air cleaners have pleated cellulose fiber elements. This material is considered most efficient for maximum cleaning ability with minimum restriction to intake air. Super-Filter air cleaners maintain high efficiency at all engine speeds and high air velocity for for best cleaning action. NOTE: If your engine is equipped with a closed crankcase ventilating system, the cleaning element is made of polyurethane and requires more frequent replacement than the cellulose fiber element.

2 Carburetion for the "289"

The four-venturi carburetor features two-stage operations, with two primary throttle plates and two vacuum-operated secondary throttle plates. For all normal driving, the engine receives the fuel-air mixture from the carburetor primary venturis. When the accelerator is depressed for rapid acceleration, the drop in engine vacuum opens the secondary venturis, increasing the fuel-air charge for greater power. This two-stage method of operation provides full-range engine operating requirements efficiently and economically. A thermostatically controlled automatic choke operates with the secondary throttle plate to provide quick, sure starts in all kinds of weather.

3 Free-Breathing Intake System

The free-breathing, direct-intake system of the high performance engines channels the fuel-air mixture from the carburetor to the combustion chambers through low-restriction passages for top distribution efficiency.

The flow of the mixture is uniform and fast-moving to provide more precise individual combustion chamber charges for efficient, high-torque engine output.

4 Intake and Exhaust Valves

The intake valves are cast of tough SAE 1047 steel. The tops and seating surfaces are aluminized for protection against burning and pitting. Damper springs help prevent valve "floating" at high engine rpm. Exhaust valves are cast austenitic steel, a solid solution of carbon in pure iron which produces an extremely hard steel that is exceptionally resistant to wear, warping and high-temperature-induced corrosion.

5 High-Lift Camshaft

Ford Motor Company camshafts are precision-molded of special alloy iron for maximum strength and wear resistance. The camshaft lobes are contoured for smooth valve action. High-lift design, plus extended valve opening periods, provides full-charge fuel-air intake and quick clearance of exhaust gases. Camshaft bearings are of the steel-backed, micro-babbitt, replaceable-insert type.

Solid Valve Lifters

Positive valve action, even at sustained high engine rpm, is possible with the solid valve lifters used on all Ford Motor Company high-performance engines.

Header-Type Exhaust System

The cast iron exhaust manifolds of the "289" engine feature individual headers from each cylinder. The headers provide efficient evacuation of the combustion chambers by reducing exhaust back pressure and interaction or "pulse" between adjoining cylinders. The headers discharge into dual exhaust pipes to provide a complete low-loss exhaust system.



289 High Performance Engine Specifications

GENERAL		INTAKE VALVES—Continued	
Type	8-cylinder 90° Vee, Overhead Valve	Spring Pressure & Length	83.5-92.5 lbs. @ 1.77" (valve closed) 234.5-259.5 lbs. @ 1.32" (valve open)
Displacement	289 Cubic Inches	EXHAUST VALVES	
Bore & Stroke	4.00" x 2.87"	Material	21-4N Forged Steel Aluminized
Compression Ratio	10.5:1	Overall Length	4.863"
Brake Horsepower	271 @ 6000 rpm	Overall Head Diameter	1.442"—1.457"
Maximum Torque	312 lbs./ft. @ 3400 rpm	Angle Of Seat & Face	44°
Valve Lifters	Solid	Lift	0.477"
Carburetor	One 4-venturi	Spring Pressure & Length	83.5-92.5 lbs. @ 1.77" (valve closed) 234.5-259.5 lbs. @ 1.32" (valve open)
Fuel	Super Premium	PISTONS	
Cylinder Block Material	Precision Cast Iron	Material	Extruded Aluminum Cam Ground
Cylinder Head Material	Precision Cast Iron	Weight	21.09 oz.
Oil Filter	Rotunda 6000 Mile Type Part Number C1AZ-6731-A (R1-A)	PISTON RINGS	
CRANKSHAFT		No. 1 Compression	Cast Iron Alloy, Straight Face, Chrome Plated
Material	Precision-Molded Alloy Cast Iron	No. 2 Compression	Cast Iron Alloy, Straight Face, Scraper Groove, Phosphate Coated
Main Bearings (5)	Steel-Back Copper-Lead Alloy Replaceable Inserts	No. 3 Oil Control	Multi-Piece, Two Rails & One Spacer Expander, Steel Rails, Chrome Plated, Oxide Coated Expander—Blued Steel
Main Bearing Journal Diameter	2.2482"—2.2490"	Width—No. 1 No. 2	0.0774"—0.0781" 0.0930"—0.0940"
Thrust Bearing	No. 3	Gap—Nos. 1 & 2 No. 3	0.010"—0.020" 0.015"—0.055"
Crankpin Journal Diameter	2.1228"—2.1236"	PISTON PINS	
CAMSHAFT		Type	Press-Fit in Rod
Material	Precision-Molded Special Alloy Iron	Material	SAE 5015 Alloy Steel, Heat Treated
Bearings (5)	Steel-Back Babbitt Inserts	Length	3.010"—3.040"
Camshaft Gear Material	Cast Iron	Diameter	0.9119"—0.9124"
VALVE SYSTEM		CONNECTING RODS	
Operating Tappet Clearance	0.018 (hot) Hot setting to be made after a minimum of 30 minutes @ 1200 rpm (no load)	Material	SAE 1041 Forged Steel, with Separately Forged Caps
Intake Valve Opens	0.008 @ 46° BTDC	Weight	20.776—21.059
Intake Valve Closes	0.010 @ 84° ABDC	Length	5.1535—5.1565
Duration	324°	CONNECTING ROD BEARINGS	
Exhaust Valve Opens	0.008 @ 94° BBDC	Material	Steel-Back Copper-Lead Alloy Inserts
Exhaust Valve Closes	0.010 @ 36° ATDC	Overall Length	0.716"—0.726"
Duration	324°	Clearance Limits	0.0009"—0.0029"
Valve Opening	96°	INTAKE VALVES	
INTAKE VALVES		Material	SAE 1047 Aluminized Steel
Material	SAE 1047 Aluminized Steel	Overall Length	4.863"
Overall Length	4.863"	Overall Head Diameter	1.662"—1.667"
Overall Head Diameter	1.662"—1.667"	Angle Of Seat	44°
Angle Of Seat	44°	Lift	0.477"
Lift	0.477"		



Performance Adjustments for the 289 Engine

GENERAL		BREAKER POINTS—Continued	
Firing Order	1-5-4-2-6-3-7-8	Standard Plug Gap Width	0.028—0.032
Valve Clearance	0.022 cold—0.018 hot	Spark Plug Torque	15-20 lbs./ft.
Cam Lobe Lift (normal)	0.298	FUEL SYSTEM	
Cam Lobe Wear Limit	0.005	Carburetor Number	C40F-9510-AL C50F-9510-L
Valve Lift (theoretical zero lash)	0.477	Main Metering Jet Identification	52F—Primary 50F—Primary 68F—Secondary 66F—Secondary
Compression Pressure (sea level)	130-170 psi	Power Valve Color (normal) (altitude)	Plain Green
Idle Manifold Vacuum	15 in. HG	Float Setting (dry) (wet)	$1\frac{5}{32}$ " Primary $2\frac{9}{64}$ " Second. $\frac{7}{8}$ " Primary $2\frac{9}{32}$ " Second.
IGNITION SYSTEM		Initial Idle Mixture Setting	1— $1\frac{1}{2}$ turns open
Initial Ignition Timing (new points)	12° BTDC	Accelerator Pump Setting	Inboard No. 3
Final Ignition Timing (tune-up)	12° BTDC	Choke Spring Housing Initial Setting	Manual
Distributor Number	C5AZ-12127-EEZ	Maximum (hot) Idle Adjustment	750-775 rpm
Centrifugal Advance (set test stand to 0 degree at 2500 rpm and 0 in. HG)	rpm	Advance Degrees	Fuel Pump Static Pressure
	650	$2\frac{1}{4}$ — $3\frac{1}{4}$	4-6 psi @ 500 rpm
	750	4 — $5\frac{1}{2}$	
	1000	$6\frac{1}{2}$ — $7\frac{1}{2}$	
	1600	$7\frac{1}{2}$ — $8\frac{3}{4}$	
2000	$8\frac{1}{2}$ — $9\frac{3}{4}$		
Maximum Advance Limit	14°	TORQUE LIMITS	
BREAKER POINTS		Intake Manifold	20-22 ft.-lbs.
Arm Spring Tension (std. ignition)	27-30 oz.	Exhaust Manifold	13-18 ft.-lbs.
Contact Spacing	0.019—0.021	Oil Pan Drain Plug	15-20 ft.-lbs.
Dwell Angle at Idle Speed std. ignition combined	30-33°	Oil Filter	With oil on gasket surface, hand tighten until gasket contacts adapter face: then tighten $\frac{1}{2}$ turn more.
Standard Spark Plugs	Part No. COAZ-12405-A (BF-32)	Connecting Rod Retaining Nut	40-45
Spark Plug Size	18MM		



MUSTANGS SHOW THEIR "TOURING CLASS"

A five-year winning streak held by Jaguar was broken in September 1964 by these two Ford Mustangs which won touring class honors in Europe's most unique race, the Tour de France. This event, which lasts for ten days, includes 3,500 miles of road rallying, eight hill climbs and a total of 12 hours of competition on eight race courses. Specially prepared and modified Mustangs won all eight of the road races, including this one at Pau, France, which shows eventual class winner Peter Procter in the lead Mustang closely followed by second-place finisher Peter Harper. Procter outlasted 56 other cars to finish the ten-day competition with no penalty points.



HIGH PERFORMANCE ENGINE



the 390 4-V 330 hp INTERCEPTOR ENGINE

The mighty Interceptor engine was designed for full-out highway performance in police and emergency vehicles—and is built to take sustained road speed punishment for hours on end. Thus it is an ideal power plant for day-to-day use where extremely fast acceleration, high power and maximum durability are desired.

This brawny 330-hp V-8 is a well-balanced combination of high-output engine features, long-life materials and precision manufacture; service-proved in law enforcement use. The Interceptor's consistent high performance is based on a free-breathing induction system with a high velocity 4-venturi carburetor, direct-flow Super-Filter air cleaner and low back-pressure mufflers. The valve system has a high-lift camshaft, solid lifters, special-alloy steel exhaust valves, high performance valve springs with solid retainers and internal damping springs.

Built-in stamina for maximum-duty use is part of the Interceptor's total performance heritage. Some of the many durability features are extra-strong deep-block construction, short-stroke design, super-fitted light-alloy pistons, heavy-duty copper-lead-alloy main and connecting rod bearings and high capacity cooling. A 42-amp. dual belt drive alternator provides continuous output to supply all electrical system requirements.

The Interceptor V-8 is unique in the high-performance engine group. This powerful Ford-built engine is available with either a 3-speed manual shift transmission, overdrive, or a heavy-duty Cruise-O-Matic transmission, as well as with the 4-speed manual transmission. The standard and overdrive transmissions have an 11" clutch. Vehicles ordered with this engine are provided with a heavy-duty suspension, Extra-Cooling Package and self-adjusting heavy-duty, fade-resistant riveted brakes.



390 Interceptor Engine Specifications

GENERAL		INTAKE VALVES—Continued	
Type	8-cylinder 90 degrees Vee, Overhead Valve	Spring Pressure & Length	80-90 lbs. @ 1.82" (valve closed) 255-280 lbs. @ 1.32" (valve open)
Displacement	390 Cubic Inches	EXHAUST VALVES	
Bore & Stroke	4.05" x 3.784"	Material	Cast Austenitic Steel-Aluminized Heads
Compression Ratio	10.1:1	Overall Length	5.426"
Brake Horsepower	330 @ 5000 rpm	Overall Head Diameter	1.551"—1.566"
Valve Lifters	Solid	Angle of Seat & Face	44°
Maximum Torque	427 lbs./ft. @ 3200 rpm	Lift	0.2636"
Carburetor	One 4-venturi	Spring Pressure & Length	80-90 lbs. @ 1.82" (valve closed) 255-280 lbs. @ 1.32" (valve open)
Fuel	Premium	PISTONS	
Exhaust	Dual	Material	Cast Aluminum with Steel Struts, full Skirts Cam Ground
Cylinder Block Material	Precision-Cast Iron	Weight	24.52 oz.
Cylinder Head Material	Precision-Cast Iron	PISTON RINGS	
Oil Filter	Rotunda 6000 Mile Type—Part No. C1AZ-6731-A (RI-A)	No. 1 Compression	Cast Iron Alloy, Straight Face, Chrome Plated
CRANKSHAFT		No. 2 Compression	Cast Iron Alloy, Straight Face, Scraper Groove, Phosphate Coated
Material	Precision Molded Alloy Cast Iron	No. 3 Oil Control	Multi Piece: Two Rails and One Spacer Expander. Rails Steel, Chrome Plated, Oxide Coated Expander—Blued Steel
Main Bearings (5)	Steel-backed Copper-Lead Alloy	Width—No. 1	0.0774"—0.0781"
Main Bearing Journal Diameter	2.7484"—2.7492"	No. 2	0.0930"—0.0940"
Thrust Bearing	No. 3	Gap—Nos. 1 & 2	0.010"—0.020"
Crankpin Journal Diameter	2.4380"—2.4388"	No. 3	0.015"—0.055"
CAMSHAFT		PISTON PINS	
Material	Precision-Molded Special Alloy Iron	Type	Full Floating Tubular
Bearings (5)	Steel-Back Babbitt Inserts	Material	SAE 5015 Alloy Steel, Heat Treated
Camshaft Gear Material	Molded Nylon on Aluminum Die Cast	Length	3.156"—3.170"
VALVE SYSTEM		Diameter	0.9750"—0.9753"
Operating Tappet Clearance	0.025" (hot) Hot setting to be made after a minimum of 30 minutes @ 1200 rpm (no load)	Bushing	Bronze
Intake Valve Opens	0.006 @ 48° BTDC	CONNECTING RODS	
Intake Valve Closes	0.008 @ 96° ABDC	Material	SAE 1041 Forged Steel with Separately Forged Caps
Duration	282°	Weight	27.0 oz.
Exhaust Valve Opens	0.006 @ 96° BBDC	Length	6.486"—6.490" Center to Center
Exhaust Valve Closes	0.008 @ 48° ATDC	CONNECTING ROD BEARINGS	
Duration	54°	Material	Steel-Back Copper-Lead Alloy Inserts
Valve Opening	54°	Overall Length	0.741"
INTAKE VALVES		Clearance Limits	0.0007"—0.0028"
Material	Special Alloy Valve Steel with Aluminum Coated Head		
Overall Length	5.446"		
Overall Head Diameter	2.022"—2.037"		
Angle of Set & Face	44°		
Lift	0.400		



Performance Adjustments for the 390 Interceptor Engine

GENERAL		FUEL SYSTEM													
Firing Order	1-5-4-2-6-3-7-8	Carburetor Number	C4AF-9510-J Std. trans. & closed crnkcs. vent system C4AF-9510-K Std. trans. & open crnkcs. vent system C4AF-9510-AR Auto. trans. & closed crnkcs. vent system C4AF-9510-AF Auto. Trans. & open crnkcs. vent system												
Valve Clearance	0.028 cold—0.025 hot	Main Metering Jet Identification	C4AF-9510-J—52F-67F C4AF-9510-AR—52F-57F C4AF-9510-K—50F-67F C4AF-9510-AS—50F-67F												
Cam Lobe Lift (normal)	0.2636	Power Valve Number													
Cam Lobe Wear Limit	0.005	Power Valve Color (normal)	Plain												
Valve Lift (theoretical zero lash)	0.400	(altitude)	Green												
Compression Pressure (sea level)	170-210 psi	Float Setting (dry)	$1\frac{5}{32}$ " Primary $2\frac{9}{64}$ " Secondary												
Idle Manifold Vacuum	18 in. HG	(wet)	$\frac{7}{8}$ " Primary $2\frac{9}{32}$ " Secondary												
IGNITION SYSTEM		Initial Idle Mixture Setting	1—1½ turns open												
Initial Ignition Timing (new points)	6° BTDC Std. trans. 6° BTDC auto trans.	Accelerator Pump Setting	No. 3 Inboard												
Final Ignition Timing (tune-up)	6° BTDC Std. trans. 6° BTDC auto trans.	Thermostatic Spring Identification	TT												
Distributor Number	C5AZ-12127-EEZ	Choke Spring Housing Initial Setting	At Index Mark												
Centrifugal Advance (set test stand to 0 degrees at 2500 rpm and 0 in. HG)	<table border="1"> <thead> <tr> <th>rpm</th> <th>Advance Degrees</th> </tr> </thead> <tbody> <tr> <td>450</td> <td>1¼ — 2¼</td> </tr> <tr> <td>500</td> <td>3¼ — 4¼</td> </tr> <tr> <td>800</td> <td>5¼ — 6¼</td> </tr> <tr> <td>1600</td> <td>9 — 10½</td> </tr> <tr> <td>2000</td> <td>10¼ — 12¼</td> </tr> </tbody> </table>	rpm	Advance Degrees	450	1¼ — 2¼	500	3¼ — 4¼	800	5¼ — 6¼	1600	9 — 10½	2000	10¼ — 12¼	Fast (cold) Idle Adjustment	1500 rpm Auto.—1300 Std.
rpm	Advance Degrees														
450	1¼ — 2¼														
500	3¼ — 4¼														
800	5¼ — 6¼														
1600	9 — 10½														
2000	10¼ — 12¼														
Maximum Advance Limit	14°	Maximum (hot) Idle Adjustment	575-600 rpm Std. Trans. 550-575 Auto. Trans.												
Vacuum Advance (set test stand to 0 degrees at 1000 rpm and 0 in. HG)	<table border="1"> <thead> <tr> <th>rpm</th> <th>Advance Degrees</th> <th>Vacuum In. HG</th> </tr> </thead> <tbody> <tr> <td>1000</td> <td>2—5</td> <td>8</td> </tr> <tr> <td>1000</td> <td>4—7</td> <td>10</td> </tr> <tr> <td>1000</td> <td>5½—8½</td> <td>14</td> </tr> </tbody> </table>	rpm	Advance Degrees	Vacuum In. HG	1000	2—5	8	1000	4—7	10	1000	5½—8½	14	Fuel Pump Static Pressure	4½—6½ psi @ 500 rpm
rpm	Advance Degrees	Vacuum In. HG													
1000	2—5	8													
1000	4—7	10													
1000	5½—8½	14													
Maximum Advance Limit	8½°	TORQUE LIMITS													
BREAKER POINTS		Intake Manifold	32-35 ft.-lbs.												
Arm Spring Tension std. ignition trans. ignition	17-21 oz.	Exhaust Manifold	12-18 ft.-lbs.												
Contact Spacing	.0014—.0016	Oil Pan Drain Plug	15-20 ft.-lbs.												
Dwell Angle at Idle Speed std. ignition combined trans. ignition	26—28½°	Oil Filter	With oil on gasket surface, hand tighten until gasket contacts adapter face; then tighten ½ turn more.												
Standard Spark Plugs	Part No. COAZ-12405-A (BF-32)	Connecting Rod Bearing Nut	53-58												
Spark Plug Size	18 MM														
Standard Plug Gap Width	0.028—0.032														
Spark Plug Torque	15-20 lbs./ft.														

POWERFUL PUNCH FOR POWERBOATS!

The fact that Ford engines pack a performance wallop on water as well as on land was demonstrated recently when Ford-powered boats captured the first three places in the famous Orange Bowl nine-hour endurance race.

The race, held in Miami, Florida, as part of the Orange Bowl festival, was the first of five major powerboat endurance events scheduled for 1965. During the 1963 season, boats with Ford engines won two of five major races. In 1964 the score was four for five.

Ford-powered boats led the Orange Bowl Regatta from start to finish. The eventual winner, Lou Brummett of Pasadena, Calif., moved into first place with one-and-a-half hours remaining and went on to win with a record average speed of 60.056 miles per hour. He also covered 568 miles to break the Orange Bowl distance record by 61 miles.

In second place for the second straight year was Mike Gordon of Miami. Both men piloted SK boats powered by Ford high-performance 427-cubic-inch engines converted for marine use by Holman and Moody, Inc., of Charlotte, N. C. Third place went to another Ford-powered SK boat piloted by Robert Nordskog of Tarzana, Calif.



Photograph by Squire



HIGH PERFORMANCE ENGINE

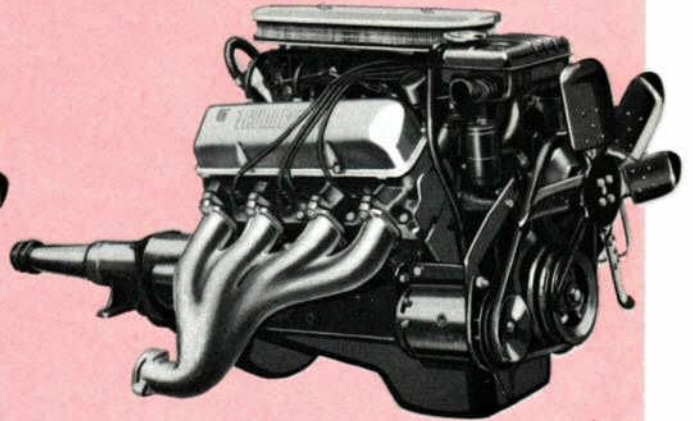

The 406 ENGINES

Two 406 cubic inch engines were introduced by Ford Motor Company in late 1961. The 405 horsepower (6V) super high performance model was the most powerful engine ever offered by Ford to that time. The 385 horsepower version was rated the most powerful 4-venturi engine in the industry. The two engines were identical except for their intake systems.

Beginning in 1962, the 406 established itself as a real performer, winning many speed events throughout the nation, not only oval track and drag races but also boat races such as the 500 Mile Marathon at Salton Sea, Calif.

Although the 406 engines are no longer in production, many are in active use and service parts are still available as shown on pages 49 through 54. Since these engines had the same basic block as the newer 427, many of the components are interchangeable.

406 V-8 High Performance Engine Specifications

Bore 4.13 in.
Stroke 3.78 in.
Firing order: 1-5-4-2-6-3-7-8

	4-V	3 2-V
Maximum B.H.P.	385 @ 5800 RPM	405 @ 5800 RPM
Maximum Torque	444 @ 3400 RPM	448 @ 3500 RPM
Compression Ratio: Nominal	10.9:1	
	Maximum 11.4:1	
Camshaft, Part No. C2AE-6250-A		
Intake opens	24° BTC	
Intake closes	72° ABC	
Duration	276°	
Exhaust opens	72° BBC	
Exhaust closes	24° ATC	
Duration	276°	
Valve overlap	48°	



PUT COBRA VENOM IN YOUR V-8!

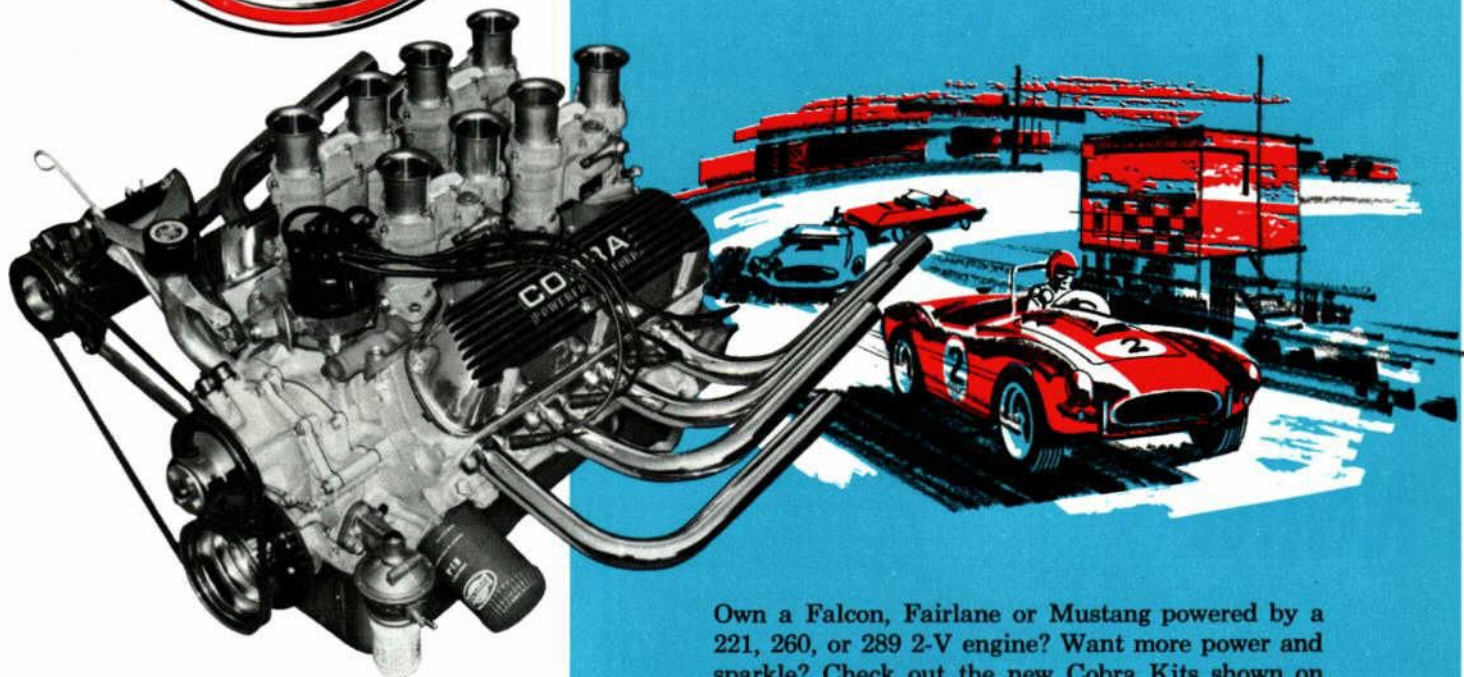

Cobra Kits on Fairlane 289 V-8
with special exhaust header pipes

Own a Falcon, Fairlane or Mustang powered by a 221, 260, or 289 2-V engine? Want more power and sparkle? Check out the new Cobra Kits shown on the following pages. Inspired by the championship performance of Ford-powered Cobras, these kits are designed to give your engine stepped-up performance, plus a gleaming, customized appearance.

Read what Ak Miller has to say about Ford's new V-8's and the new Cobra Kits . . .

In recent years Ford Fairlane V-8's have been accepted and admired by the motoring world like no other engine in the past. A broad statement admittedly, but one that's backed by the records these fine engines have set for reliability and power output, and their wide popularity with performance-minded car owners.

The basic Fairlane engine is a natural for power-increase modifications because it's designed for high volumetric efficiency and has the advantages of low piston speeds, and short-stroke compactness. The strength and rigidity inherent to Fairlane engine design has permitted output to be boosted to the present 271 horsepower—a dramatic demonstration of its built-in strength. These amazing boosts in power were made by modifying without altering the engine's basic compact dimensions.



“...racing provided a tough proving ground for testing special engine modification parts...”

Along with setting new records, the Fairlane engine's applications in racing provided a tough proving ground for testing special engine modification parts developed for high speed operation. Because this testing proved these components more than suitable for general use, they are now being offered to enthusiasts who want to get more power and performance from their standard 221, 260, or 289 cubic-inch V-8 engine. These competition-bred parts are sold in kit form, ranging from special, high-compression cylinder heads to a low-restriction exhaust system.

The performance-minded motorist who doesn't want to go all-out on these kits will find it possible to get a substantial power increase by using just the equipment appropriate to his budget or driving needs. For instance, if one wanted only a moderate 10 to 14 horsepower boost, the single 4-V induction kit would probably do the job. On the other hand, if you were after all-out performance, the ultimate, of course, would be the Cobra/Weber 4-2V induction kit. Horsepower carries a price tag, but by careful selection one can pick out kits that will produce the performance desired at a reasonable cost.

In addition to parts that deliver better performance, there are items for your safety and your engine's, too: The high-carbon, cast-steel scatter shield is designed to provide increased protection for you and your passengers. The increased capacity of a competition oil pan provides an extra safety margin for proper lubrication of a high performance engine. Appearance hasn't been forgotten, either, Cobra dress-up kits can make your car's engine a real eye-catcher.

Cobra kit variety, and the sturdy reliability of the basic design of these engines, facilitate custom modification of Fairlane V-8's to almost any degree of performance and appearance desired.

The opportunity to obtain additional power from your engine without going to the cost of radical machining is given to you through Ford's wide selection of tested and proven Cobra Kits—all you have to do is install them, tune'er up, and enjoy winning performance with a touch of the throttle.



Cobra Kits for 221, 260 and 289 Engines

ENGINE PERFORMANCE KIT

Here's a three-way power package for 221, 260 and 289 blocks. Has eight matched pistons with heads designed for valve clearance; high-lift design cam with solid lifters; cylinder head and valve assemblies with heavy-duty rocker arm studs, spring seat ridges, solid valve spring retainers and oil-controlling valve stem seals. Cobra Medallions included.

- 221 Kit—C40Z-6A044-A Fits 1962-63 Fairlane 221
 260 Kit—C40Z-6A044-B Fits 1962-64 Falcon 260
 • 1962-64 Fairlane 260
 • 1965 Mustang 260
 289 Kit—C40Z-6A044-C Fits 1962-65 Fairlane 289
 • 1962-65 Falcon 289
 • 1965 Mustang 289

Each \$345.25*



COBRA CYLINDER HEAD AND VALVE KIT

These cylinder heads have heavy-duty threaded rocker arm studs to resist loosening, spring seat ridges to help keep valve springs and dampers aligned and solid valve spring retainers and oil controlling valve stem seals. Intake valve head diameter is 1.665"; exhaust, 1.445". Both are aluminized and have polished chrome plated stems. Exhaust valves are forged heat resistant chrome manganese alloy and fit 221, 260 and 289 CID V-8's. Kit includes 2 cylinder heads, 8 intake valves, 8 exhaust valves, 16 valve damper assemblies, 16 stem seals, 16 valve spring retainers, 32 key valve spring retainers, and 2 Cobra medallions. This kit fits all three blocks and can be bought separately.

- Part Number—C40Z-6C056-A Fits 1962-65 Falcon 260
 & 289, Fairlane 221, 260
 & 289 • 1965 Mustang
 260 & 289

\$224.25*



Authentic Cobra Medallions

A pair of these colorful, attractive Cobra medallions are included in the following Cobra Kits:

PART NUMBER	COBRA KIT
C40Z-6A044-A	221 Engine Performance Kit
C40Z-6A044-B	260 Engine Performance Kit
C40Z-6A044-C	289 Engine Performance Kit
C40Z-6C056-A	Cylinder Head and Valve Kit
C40Z-6B068-A	3-2V Induction Kit (260 Eng.)
C40Z-6B068-B	3-2V Induction Kit (289 Eng.)
C40Z-6B068-D	Single 4V Induction Kit
C40Z-6B068-E	2-4V Induction Kit
C40Z-6A257-A	Cam Kit



The Cobra medallions can be mounted anywhere on car bodies by using the spring nuts provided.

*Manufacturer's suggested retail prices. Installation charges, state and local taxes, if any, are extra.



Cobra Kits for 221, 260 and 289 Engines

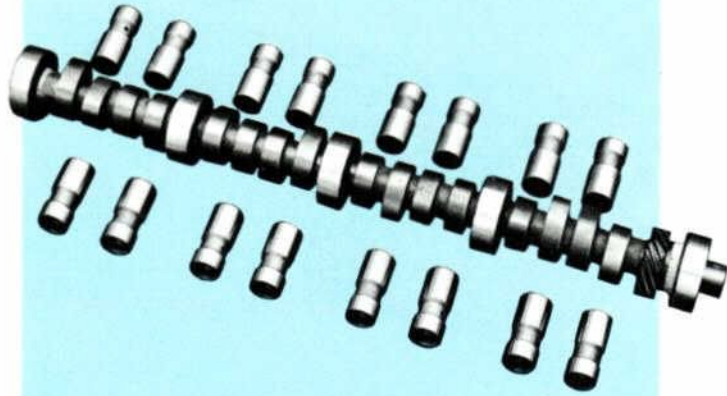

CAM KIT

This kit has been specially engineered with correct tolerances for Ford 221, 260, 289 blocks. Consists of finely machined camshaft and 16 tappets and is the same type used in winning Cobras. Kit includes Cobra medallions.

Part Number—C4OZ-6A257-A . . . Fits 1963-65 Falcon 260 & 289 • 1962-65 Fairlane 221, 260 & 289 • 1962-65 Ford 260 & 289 • 1965 Mustang 260 & 289

\$75.10*



DISTRIBUTOR KIT

This high-performance kit consists of heavy-duty distributor and leads. Features dual points, centrifugal spark advance. Use the kit to give your engine the high-speed performance characteristics you want that are especially suited for drag strip operations and other high RPM requirements.

Part Number—C4DZ-12050-A . . . Fits 1963-65 Ford 260 & 289 • 1963-65 Falcon 260 & 289 • 1963-65 Fairlane 260 & 289 • 1965 Mustang 260 & 289

\$49.80*

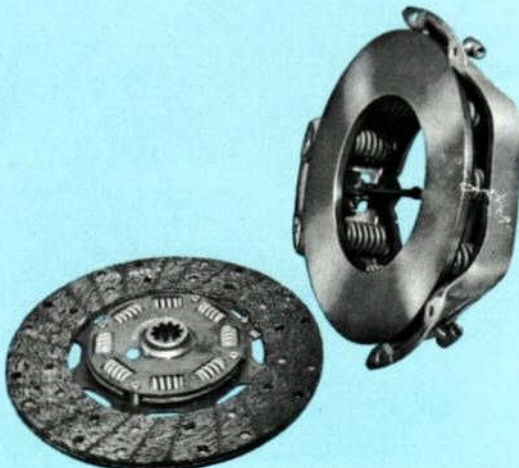

HEAVY-DUTY CLUTCH KIT

This kit consists of disc assembly and pressure plate. Construction of both the plate and disc assembly virtually eliminates slipping and provides maximum performance under demanding conditions.

Part Number—C3OZ-7A537-A . . . Fits 1963-65 Falcon 260 & 289 • 1963-65 Fairlane 221, 260 & 289 • 1965 Mustang 260 & 289

\$51.45*

*Manufacturer's suggested retail prices. Installation charges, state and local taxes, if any, are extra.



Cobra Kits for 221, 260 and 289 Engines

COMPETITION OIL PAN

Sturdy, cast aluminum competition-type oil pan features air cooling fins for improved oil temperature control. Also has large 6½ quart capacity for added engine protection under prolonged hot operation. Fits all three engines.

Part Number—C4OZ-6675-A . Fits 1963-65 Falcon 260 •
1965 Mustang 260 &
289

\$80.80*



DUAL EXHAUST KIT

For converting standard exhaust systems to dual systems. This kit includes pipe, necessary hardware, and two straight-through 4-inch glass pack mufflers to improve performance and increase horsepower rating. Fits 1963-64 Falcon 260 V-8.

Part Number—C4DZ-5210-A . Fits 1963-64 Falcon 260

\$69.95*

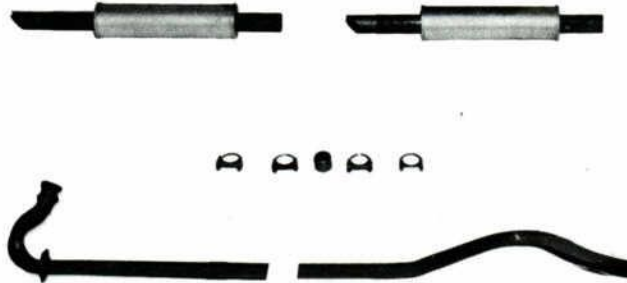

SCATTER SHIELD

Made of high-carbon cast steel, this housing is designed to give extra protection for occupants and car especially at high engine speeds. This replaces the cast aluminum cover.

Part Number—C4OZ-6394-A . Fits 1962-64 Falcon 260 &
289 • 1962-64 Fairlane
221, 260 & 289 •
1962-64 Ford 260 &
289 • 1965 Mustang
260 & 289

\$106.75*





Cobra Kits for 221, 260 and 289 Engines

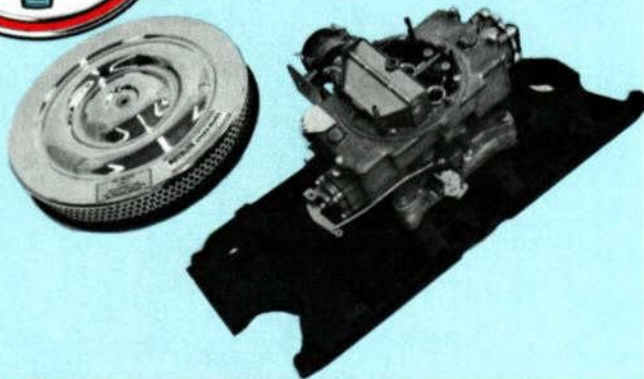

SINGLE 4-V INDUCTION KIT

This 4-V will give you greater performance without drastic modification of your mill. Kit has intake manifold, air cleaner, 4-V carburetor, required gaskets, necessary hardware.

Part Number—C4OZ-6B068-D . . . Fits 1962-64 Falcon 260 & 289 • 1962-64 Fairlane 221, 260 & 289

C5ZZ-6B068-A . . . Fits 1965 Falcon 289 •

1965 Fairlane 289 • 1965 Mustang 260 & 289

Cobra Medallions included **\$122.60***

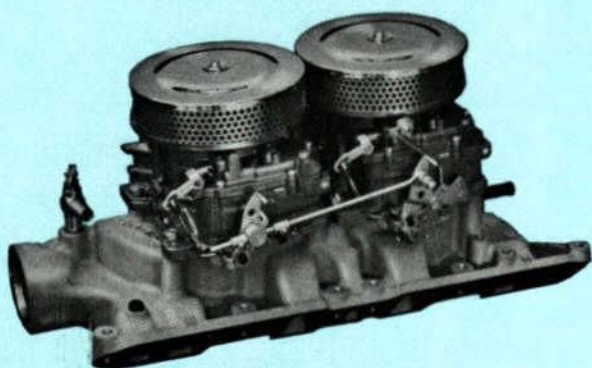

TWO 4-V INDUCTION KIT

This kit contains two of the carburetors used in the Single 4-V Kit, plus a specially designed cast-aluminum intake manifold. Primary sections of carburetors operate progressively from throttle linkage for starting and/or low and medium speeds. Both secondaries are velocity-flow operated to cut in for acceleration and high speed use. Kit includes 1 intake manifold, 2 carburetors, 2 air cleaners, and 2 Cobra Medallions.

Part Number—C4OZ-6B068-E . . . Fits 1963-65 Ford, Falcon • Fairlane 260 & 289 • 1965 Mustang 260 & 289

Linkage Kits: **\$245.00***

Part Number—C5DZ-9B843-A . . . Fits 1963-65 Fairlane Auto Trans. • 1963-65 Falcon Auto Trans.

\$56.98*

C5ZZ-9B843-D . . . Fits 1965 Mustang Std. Trans.

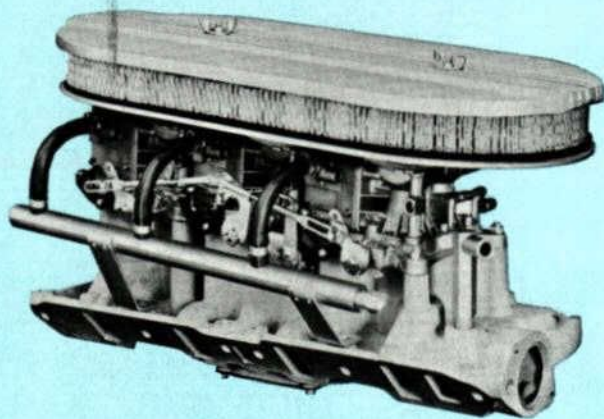

THREE 2-V INDUCTION KIT

Match this kit with the distributor and engine performance kits and watch the horses soar! Kit has three 2-V carburetors on cast-aluminum intake manifold special air cleaner. Mechanical linkage lets you "go on one" for economy, cut in the other two for maximum go under high-performance conditions. Cobra medallions also included.

260 Kit—C4OZ-6B068-A . . . 1963-64 Falcon, Fairlane 260—**\$212.55***

260 Kit—C4DZ-6B068-A 1965 Mustang—**\$210.00***

289 Kit—C4OZ-6B068-B . . . 1963-65 Falcon, Fairlane 289—**\$212.55***

289 Kit—C4DZ-6B068-B 1965 Mustang—**\$210.00***

Linkage Kits:

C3DZ-9B843-A Fits 1963 Falcon 260—**\$8.50***

C4DZ-9B843-A . . . Fits 1964-65 Falcon 260 & 289—**\$8.50***

C4OZ-9B843-A . . . Fits 1963-65 Fairlane 260 & 289—**\$8.50***

C4OZ-9B843-B . . . Fits 1964-65 Falcon, Fairlane 2 Speed Auto. Trans.—**\$8.50***

C5ZZ-9B843-A 1965 Mustang 260, 289 (Std. Trans.)—**\$8.50***

Emission Reduction Kit—C4OZ-6A603-A Fits 1963 Fairlane 289—**\$6.90***

*Manufacturer's suggested retail prices. Installation charges, state and local taxes, if any, are extra.



Cobra Kits for 221, 260 and 289 Engines

FOUR 2-V WEBER INDUCTION KIT

Consisting of four Weber carburetors and a special intake manifold, this system is designed for those who want to make a competition car with the 289 block. This off-the-street carburetor assembly is virtually the same model as used on the Ford powered Lotus. This kit fits 221, 260, and 289 engines, and includes 1 intake manifold, 4 carburetors, 1 water and fuel manifold with appropriate throttle linkage available separately.

Part Number—C5OZ-6B068-A ... Fits 1963-65 Falcon 260 & 289 • 1963-65 Fairlane 260 & 289 • 1965 Mustang 260 & 289 • **\$1,232.30***

Linkage Kits—C5OZ-9B843-A 1963-65 Falcon 260 & 289 • 1963-65 Fairlane 260 & 289 • **\$56.95***
C5ZZ-9B843-C ... 1965 Mustang 260 & 289 • **\$56.95***

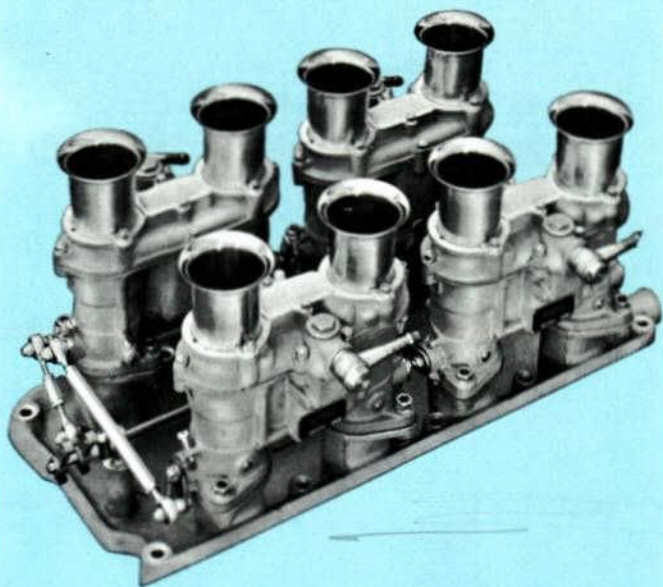

ENGINE DRESS-UP KIT

Adds a racy "Cobra" look to your engine. This stylish kit includes finned, polished aluminum valve covers; long-lasting chrome dip stick, radiator cap, master cylinder cap, oil filler cap, air cleaner cover and filter. 1963 kit fits 221, 260 and 289 Ford V-8 blocks; '64 kit fits 260 and 289 engines.

Part Number—C3OZ-6980-A ('63) **\$72.45***
C4OZ-6980-A ('64) **\$78.35***

Part Number—C3OZ-6980-A for 1963 fits 1962-63 Fairlane 221, 260 & 289 • 1962-63 Falcon 221, 260 & 289

Part Number—C4OZ-6980-A for 1964 fits 1964 Falcon 260 • 1964 Fairlane 260 & 289 • 1965 Mustang 289

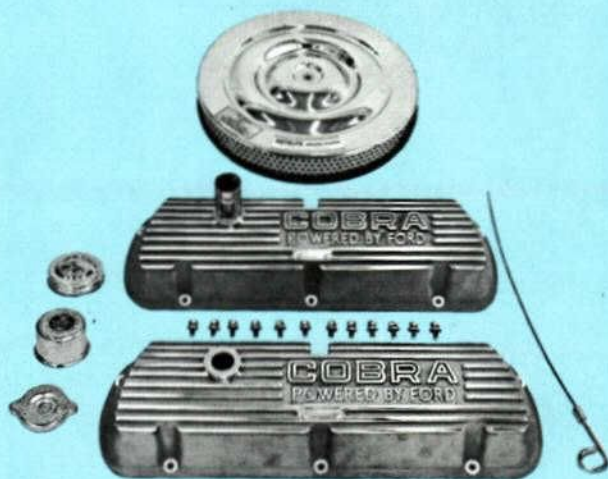

VALVE COVER KITS

Featuring polished aluminum valve covers, these kits include 2 valve cover assemblies, 12 chrome bolts and 12 chrome washers.

Part No.—C3OZ-6A547-A Fits 1962-63 Fairlane 221, 260 & 289 • 1962-63 Falcon 260—**\$42.00**

C4OZ-6A547-A for 1964 Fits 1964 Falcon 260 • 1964 Fairlane 260 & 289 • 1965 Mustang 260 & 289—**\$47.85***



*Manufacturer's suggested retail prices. Installation charges, state and local taxes, if any, are extra.



Cobra horsepower potential

by SHELBY-AMERICAN

HOW TO USE CHART BELOW: Choose engine from top of columns at left if you are interested in horsepower—260 engine, Col. A—289 4-V engine, Col. B. Read down left hand column to select HP increase. Then determine components used to gain HP increase by reading across to right. Code letter "A" indicates component listed above was used on 260 engine—code letter "B," component was used on 289 4-V engine.

Columns at far right give peak torque obtained using same equipment.

FIGURES WERE OBTAINED FROM ACTUAL DYNAMOMETER TEST PROGRAMS
by SHELBY-AMERICAN, INC.

HORSEPOWER AT RPM																PEAK (lbs.-ft.) TORQUE AT RPM		
A	B															A	B	
260 CID	289 CID (4-V)	Heavy-duty Distributor spark plug leads	Autolite BF-32 spark plugs	Emission valve plugged	Cobra Cam Kit	Compound valve springs	Cobra Cylinder Head Kit	Reworked 4-V heads: ported, enlarged comb. chambers	Steel shim cyl. head gaskets	289 4-V High Performance Exh. Manifolds	Competition (rubing) exh. headers	4-V (1-4V) Induction Kit	8-V (2-4V) Induction Kit	6-V (3-2V) Induction Kit	8-V (4-2V) Weber Kit	Generator disconnected	260 CID	289 CID (4-V)
141 at 4500 (STOCK RATING)	232 at 5500		B									B				AB	227 at 2500 (STOCK RATING)	282 at 4000
145 at 4500	242 at 6000	AB	AB	AB								B				AB	228 at 2500	289 at 3500
161 at 5000	247 at 5500	AB	AB	AB	A	A			B			B				AB	217 at 3000	295 at 3500
	249 at 5500	B	B	B				B	B	B						B	228 at 4000	296 at 3500
205 at 5500	276 at 6000	AB	AB	AB	A	A		B	AB		B	A			AB	232 at 3500	285 at 4000	
220 at 5500	286 at 6500	AB	AB	AB	A	A		B	B	AB	AB				AB	228 at 3500	286 at 4500	
211 at 5500	314 at 6500	AB	AB	AB	A		A	B	B	AB			A		AB	230 at 4000	286 at 4500	
207 at 6000	345 at 6500	AB	A	AB	A		A	B	B	A	B		A	B	AB	232 at 3500	286 at 4500	
213 at 6000		A	A	A	A		A				A		A		A	230 at 3500	313 at 5000	
222 at 5500		A	A	A	A	A					A	A				240 at 4000		
225 at 5500		A	A	A	A		A				A	A				244 at 4000		

1. The 289 4-V engine used Autolite type BTF-1 spark plugs up to 276 hp; higher readings were obtained using type BF-603.

Conversion Notes

221 CID Engine—

Cobra Kits and other 289 High Performance equipment can be installed on the 221 CID engine to produce better than 200 horsepower. However, the smaller displacement of this engine will not allow the power boosts obtainable from highly modified 260 or 289 CID engines.

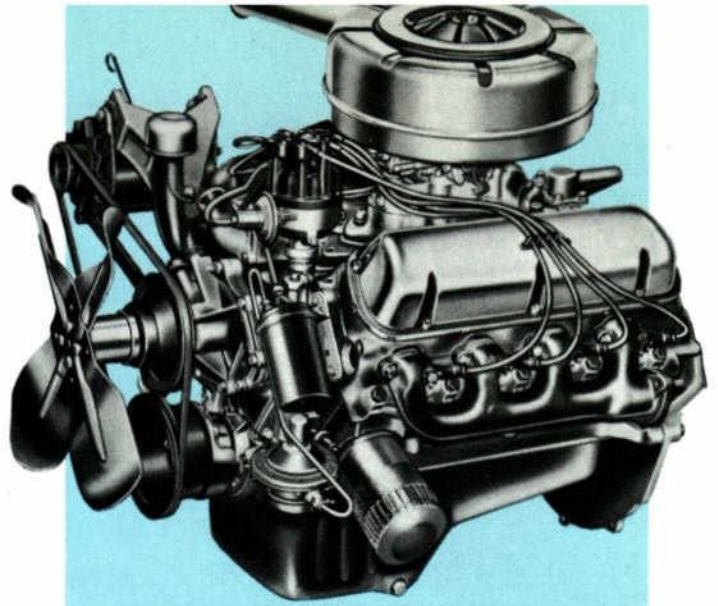

260 CID Engine—

The stock 289 4-V High Performance camshaft and solid valve lifters can be used with 260 cylinder heads, and the 289 4-V heavy-duty valve springs can be used with the stock 260 retainers. Screw-in rocker arm studs are not necessary if operation is held below 6000 RPM.

Caution, the 260 CID cylinder block cannot be bored-out to equal the four-inch bore of the 289 CID block.

The Cobra Induction Kits should be used in combination with the 289 4-V camshaft kit and heavy-duty valve springs to best obtain maximum engine speed, power and reliability.

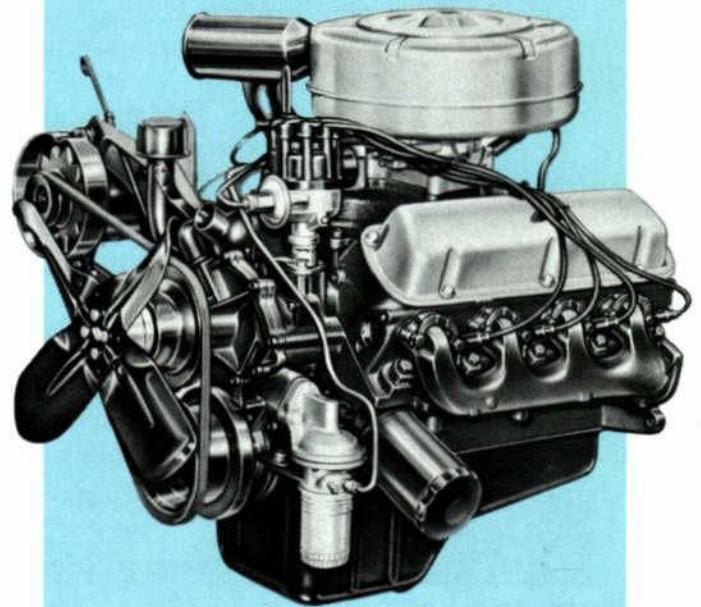

289 CID Engine—

Although the *High Performance* 289 V-8 is delivered with a 4-V carburetor, additional carburetion is available if premium performance is desired. Since many performance features are a part of this engine's standard equipment, modification is largely a matter of choosing the proper induction system for the type of operation planned for the car.

Tests of power increases from the 289 engine were made for the all-out race preparation of Carroll Shelby's King-Cobras. The horsepower figures shown on the chart on page 35 reveal the results of these tests.

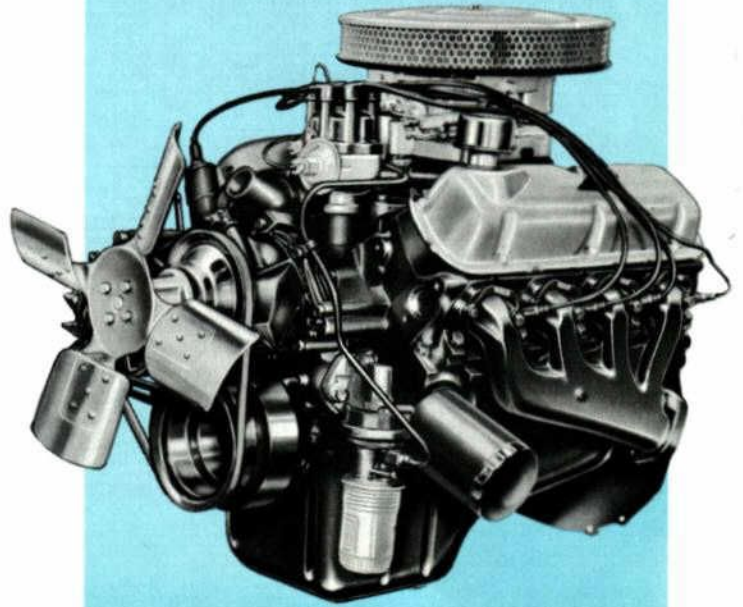

Tips and precautions for all engines

Although the Cobra Kit line is actually a series of kits, they have been designed for maximum compatibility with each other. The kits provide a wide choice and also separate the equipment into *Street and Competition* or *All-Out Competition* packages. Development emphasis, however, has been for the enthusiast who uses his car for both normal street driving and occasional competition.

Dynamometer tests of Fairlane V-8 engines modified with Cobra Kits have shown their performance ability under a great variety of conditions. Therefore, it will benefit the prospective buyer to check the chart on page 35. It illustrates the combinations of equipment used to obtain various horsepower increases at different engine speeds.

Factory clearances, stock High Performance camshaft and conventional mechanically operated distributor are used to obtain significant power increases. Nevertheless, certain preparations—as well as specific precautions—are desirable, no matter which engine you're working with.

■ The Cobra dual-point distributor kit with solid wire spark plug leads should be installed to draw the best performance from any of the other Cobra Kits.

■ For all-out performance, compound valve springs are necessary and should be matched as closely as possible using a spring tester and shim stock.

■ A substitute or altered crankshaft assembly should be rebalanced before installation. If the heavy-duty clutch kit is used, it should be attached before rebalancing.

■ For top efficiency, a dual exhaust system should be installed in place of the single one.

■ The 289 High Performance connecting rods are desirable for modified 221, 260 and 289 2-V engines (rebalancing of the crankshaft assembly is required).

■ The 289 4-V cylinder head and valve assembly may be used without the specially designed "eyebrow-ed" pistons if the correct stock head gaskets are used.

■ When fitting 289 4-V cylinder heads to a 289 2-V,

260- or 221-inch block, be sure to use the stock gasket for the engine *block*, not the heads.

■ The 289 4-V camshaft can be used in all other engines, and without the 4-V cylinder heads, but care must be taken to use the proper head gasket (proper for the block) to provide sufficient valve clearance.

■ The 4-V High Performance cylinder heads are stock, production line parts and are not ported, relieved or polished, but may be machined if desired.

■ 289 High Performance exhaust manifolds are not recommended for Falcon installations; extensive reworking of the engine compartment is required.

■ In assembling your improved engine, remember to use standard head gaskets designed for your engine block. Thinner ones can cause serious valve and piston damage.

■ Torque sequence and ratings are extremely important to proper installation of both manifold and cylinder heads.

■ The Weber carburetor induction system is recommended for "competition-only" application.

■ The Cobra Combination Engine Performance Kit should not be used in cars equipped with automatic transmissions.

Get additional advice on your High Performance Kit or power problems. Write to Ak Miller, Ford Performance Advisor, P.O. Box 627, Dearborn, Michigan.

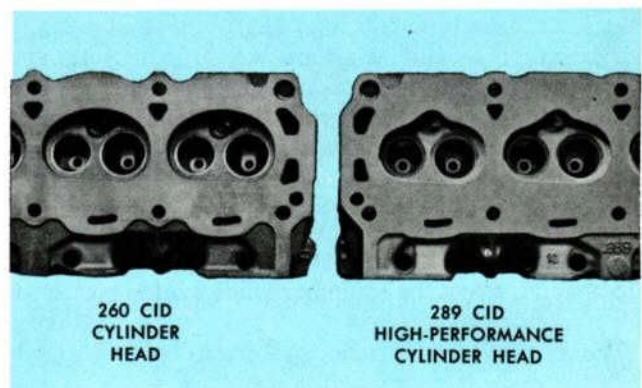

Larger, better breathing valves, reworked combustion chamber of 289 high-performance heads raise 260 engine's compression ratio to 10.5 to 1. These heads can also be used to help boost power on a 221 CID engine.

GENERAL MODIFICATION

Do's and Don'ts

by AK MILLER

Ak Miller, one of America's top authorities on high performance equipment gives his views and answers questions for those in need of expert advice on the selection and installation of engine modification components. Ak Miller's opinions and advice are his own and do not necessarily represent recommendations of the Ford Motor Company.

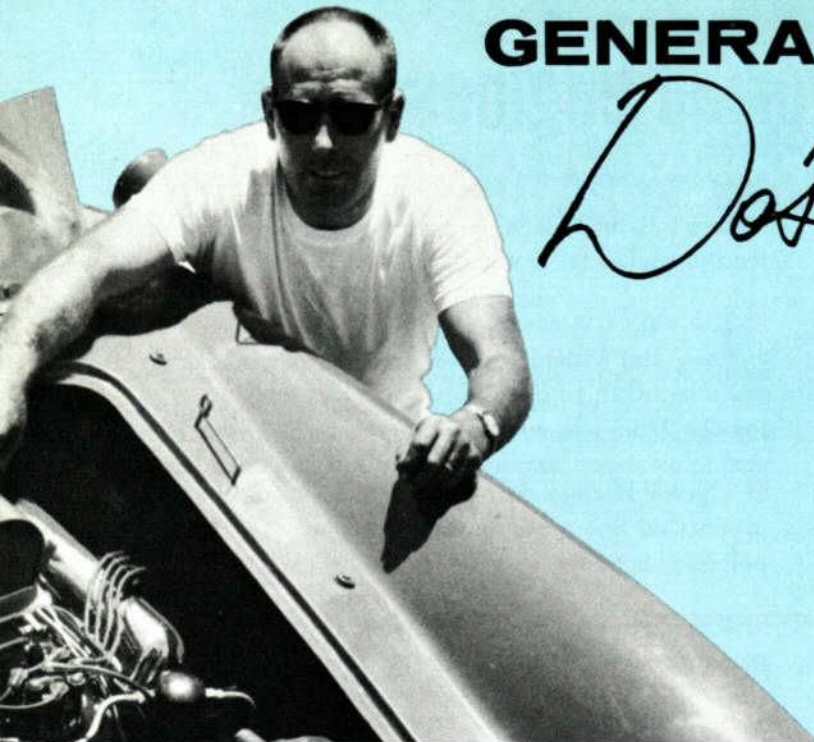

Hopping up or modifying the modern passenger car engine has caught on in a big way, especially since automobile manufacturers, such as Ford, are offering their own brand of performance equipment, with most of the items found in production high performance vehicles. For this reason, one is assured of high quality merchandise that has been thoroughly tested and evaluated. This is undoubtedly one of the big reasons why more and more people are making slight alterations or, in some cases, even major modifications for improved performance.

When modifying an engine for more horsepower, the items most generally affected are known as the Three C's. They are: COMPRESSION, CARBURETION and CAMSHAFTS. They all play a very important part in the overall performance picture and Ford owners have a host of such factory options to choose from.

As an example: For our 390 cubic inch engine, Ford offers carburetion setups starting with the 2-V, then the single 4-V, the three 2-V, and finally the dual 4-V unit. In addition, several camshafts which utilize different timing events are offered—from 256° to 324°. Special exhaust manifolds are also available. These are just a few of the many components for this engine.

The question then arises—What would be the best setup for my particular car? There are many factors to be considered when choosing performance equipment. In general, select the equipment that would produce the

most horsepower and at the same time would be compatible with your present equipment and with your driving conditions. For instance, with automatic transmissions, I would recommend camshafts of low timing events so as to keep a reasonable idle, plus a good low end torque curve. By all means, DO NOT utilize an all-out wild camshaft when the vehicle is used mostly for street driving. However, if a trip to the local dragstrip is your cup of tea and if you have a 4-speed transmission, then go all-out with the camshaft, but remember to install the related components such as the high performance springs and retainers and rockers. Therefore, we can say DO NOT install wild camshafts with automatic transmissions for general street usage.

Also, DO NOT install an exceedingly large amount of carburetion unless you are going to use it because if we put too much carburetion on an engine used mostly for ordinary street driving, we are apt to encounter flat spots due to opening up too large a venturi area resulting in sluggish gas movements in the induction system.

Indeed, the DO NOT'S of the performance field are rather small when compared to the vast number of items one can install for added performance with very gratifying results. With a little judicious planning and common sense, the installation of additional horsepower can be a most worthwhile experience and if one will observe the general rules mentioned above, he will insure a happy and successful conclusion to his performance planning.



Other High Performance Equipment

Here's new "Go" and "Show" in High Performance and Dress-Up Kits for 352, 390, 406 and 427 Blocks



HIGH PERFORMANCE KIT

Specially designed to give 390, 406 and 427 C.I.D. Ford blocks more power and performance, this kit features three 2-venturi carburetors on a precision-cast aluminum intake manifold—plus special air cleaner. Mechanically operated linkage lets you "run on one" for economy, cut in the other two for maximum "go."

Part Number—C4AZ-6B068-A \$206.66*



ENGINE DRESS-UP KIT

You can give your 352, 390 or 427 engine compartment a sparkling "show" appearance with this kit. The kit includes gleaming valve covers, air cleaner cover and oil breather cap, brake master cylinder cover, dip stick, radiator cap, fuel filter and fan guard shroud. All of the components are in stylish satin-chrome finish.

Part Number—C4AZ-6980-A \$48.20*



Other High Performance Equipment

TACHOMETERS

*For All Performance Requirements
A Model For Every Car!*

Driving can be more efficient and more economical in a car equipped with one of these precision tachometers. Easy-to-read, accurate RPM indications let you know the best shift points . . . help you get top performance from your engine. There's a High Performance Tachometer that fits your requirements. All are illuminated for night use. All have an external "zero" corrector. All can be used with regular or transistorized ignitions. All come complete with installation instructions.

- 1** 8 cylinder engines—12 volt systems/9000 RPM

FOUR-INCH FACE

Sun model for high performance cars. 250° dial gives easy, accurate readings through entire range. Pointer adjusts for setting to shift point. Tach head mounts in instrument panel. (Case and bracket kit is available for external mounting.) Completely insulated transmitter is sealed against dust and moisture.

Part Number—C4AZ-17A326-A \$60.00*

CASE AND BRACKET KIT

Satin Chrome finish for mounting 9000 RPM tachometer on any flat or curved surface or on steering column.

Part Number—C4AZ-17368-A \$6.10*

- 2** 6 and 8 cylinder engines—6, 12 volt systems/6000 RPM

THREE-INCH FACE

Complete with case and bracket. Can be mounted on top of or below instrument panel. Face rotates within head so dial is right-side-up in any location.

Part Number—C3RZ-17A326-A, 6 cylinder \$35.40*

C3RZ-17A326-B, 8 cylinder \$35.40*

- 3** 8 cylinder engines—6, 12 volt systems/8000 RPM

FOUR-INCH FACE: For high RPM demands.†

Part Number—C2RZ-17A326-B \$31.75*

- 4** 6 cylinder engines—6, 12 volt systems/5000 RPM

FOUR-INCH FACE: For standard engines.†

Part Number—C2RZ-17A326-C \$31.75*

CASE AND BRACKET KIT

Satin Chrome finish, to mount 8000 RPM or 5000 RPM tach on flat or curved surface on steering column.

- 5** Part Number—C2RZ-17368-B \$6.10*

†Tach head for both models mounts in instrument panel, contains complete unit, Hooks up to ignition inside passenger compartment.

*Manufacturer's suggested retail prices. Installation charges, state and local taxes, if any, are extra.

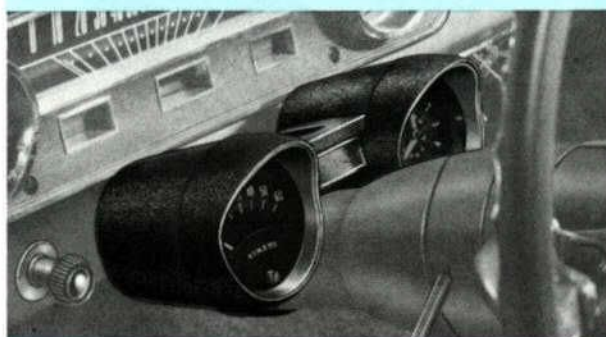

EXCLUSIVELY MUSTANG... RALLY PAC

The optional Rally Pac is essential on competition cars and attractive to anyone who has the spirit of a sports car driver.

This unique illuminated twin-pod cluster has a 6,000 or 8,000 rpm tachometer and precision clock. Has a hooded cover with "camera case" finish. Mounts on the steering column.

Part Number—C5ZZ-10B960-B

(6,000 rpm—6 cyl.) \$75.95*

Part Number—C5ZZ-10B960-C

(8,000 rpm—8 cyl.) \$75.95*



Other High Performance Equipment

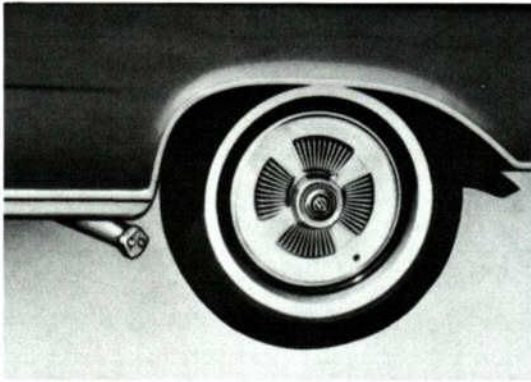

LAKE PIPES

For the performance enthusiast who wants to cut back-pressure and add horsepower. T-type of installation on manifold pipe . . . bright chrome ends . . . universal adapters for all models with 1 $\frac{3}{4}$ " and 2" pipes.

Part Number—C4AZ-5C246-A \$57.00*

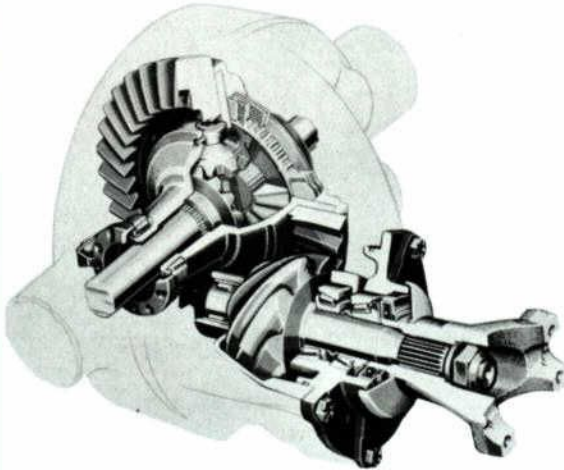

LIMITED SLIP DIFFERENTIAL

Designed to operate automatically, transmitting engine power to the rear wheels in the exact ratio to the traction resistance of both wheels so that wheel spin is virtually eliminated. Particularly suited to competition, since it is designed to give faster in-line starts and solid-axle performance on the straightaway, with minimum power loss on curves.

Basic Number—4880 \$42.00*



MUSTANG STYLED STEEL WHEELS

Add a distinctive touch of elegance to your Mustang with a set of these beautifully designed and chromed steel wheels. Quality engineered for precision fit . . . easy to install, in place of standard wheels and wheel covers.

Part Numbers—C5ZZ-1007-A (wheel),
C5ZZ-1012-A (hub nut),
C5ZZ-1130-G (hub cap)

Wheel with cap and lugs \$44.50*

*Manufacturer's suggested retail prices. Installation charges, state and local taxes, if any, are extra.



Other High Performance Equipment



HIGH PERFORMANCE EXHAUST MANIFOLDS

These exhaust manifolds are the large, branched type to provide "free breathing" for complete expulsion of gases to make room for greater air intake. They are engineered to reduce back pressure and add to horsepower output. Although released for the 427 engine, these High Performance Manifolds are easily adaptable to the 390 engine.

Part Nos.—C3AZ-9430-C (L.H.), C3AZ-9431-F (R.H.)

\$34.50*



AUTOLITE RACING SPARK PLUGS

These plugs have sparked winners from Riverside to Daytona. And no wonder! They have special high-temperature alloys in both side and center electrodes for greater efficiency, quickest starts and smoothest performance . . . resist highest combustion chamber temperatures. Autolite Racing Plugs' power tips heat up rapidly at lower speeds to burn away performance-cutting deposits, guard against preignition overheating.

18 MM TAPERED SEAT

Part Nos.—C2AZ-12405-A—Standard Gap Racing Plug (colder) (Autolite BF 601)

C2AZ-12405-B—Standard Gap Racing Plug (warmer) (Autolite BTF 1)

C3AZ-12405-A—Self-Cleaning Power-Tip Plug (warmer) (Autolite BF 22)

C3AZ-12405-B—Self-Cleaning Power-Tip Plug (colder) (Autolite BF 12)

Each \$1.08*



SOLID WIRE CORE SPARK PLUG WIRES

These wiring kits are of the "universal" type—they can be "tailored" for use on 1949 and later vehicles. An installation procedure is included with each kit. Because this type of wiring is not radio resistant, Radio Interference Suppression Kits (part numbers C4AZ-18827-A or -B) should be used with this type of wiring.

Part Nos.—A9AZ-12259-C (6 Cyl. Wire Kit) **\$5.80***

A9AZ-12259-D (8 Cyl. Wire Kit) **\$8.50***

C4AZ-18827-A (8 Cyl. Suppression Kit) **\$8.10***

C4AZ-18827-B (6 Cyl. Suppression Kit) **\$6.30***

*Manufacturer's suggested retail prices. Installation charges, state and local taxes, if any, are extra.



HIGH PERFORMANCE GENERAL PARTS LISTS

On the following pages, you will find listings of many of the parts available from your local Ford dealer for servicing and modifying vehicles equipped with Ford high performance engines:

- 427 High Performance Engine General Parts List.....pages 43 to 49
- 427 Engine Extremely Competitive Components Special Order Parts Listing.....pages 60, 61 and 62
- 352, 390 and 406 High Performance Engines General Parts List.....pages 49 to 54
- 289 High Performance Engine General Parts List.....pages 54 to 59

In order to get the best possible service, it is suggested that you contact the parts or service manager of your local Ford dealership and review with him the specific parts required. If you wish to order major assemblies, such as transmissions, rear axles, carburetors or alternators, it is helpful if you furnish as complete information as you can. For example, if you wish to replace a major component, any stampings or tags on the unit should be checked for numbers or other data which will assist in identifying the proper assembly.

ABBREVIATIONS

Assy.	Assembly	RPM	Revolutions Per Minute
CID	Cubic Inch Displacement	Std.	Standard
C4	3 Speed Dual Range Automatic Transmission	W/4/S	Warner 4 Speed Transmission
F/4/S	Ford 4 Speed Transmission	3/S/T	3 Speed Transmission
H/D	Heavy Duty	4/S/T	4 Speed Transmission
HP	Horsepower	4V	4 Venturi Carburetor
L.H.	Left Hand	6V	6 Venturi Carburetor
O/D	Overdrive	8V	8 Venturi Carburetor
R.H.	Right Hand		

Mfrs. Sugg. Retail Price } Manufacturer's suggested retail price. Installation charges and state and local taxes, if any, are extra. Prices are subject to change without notice.

NOTE: The code letters A, B, C, etc., in the "CLASS" column are provided to assist Ford dealers in ordering the specific parts.



FORD 427 ENGINE HIGH PERFORMANCE GENERAL PARTS LISTS

(For a listing of components for extremely competitive events, see page 60.)

Year	Part Number	Description	Mfrs. Sugg. Retail Price	Class	Year	Part Number	Description	Mfrs. Sugg. Retail Price	Class
WHEELS AND BRAKES					63-64	LF-3357-A	Steering Idler Arm Bushing	1.00	CY
63-65	C1AA-1177-A	Seal—Rear Wheel Bearing Oil—Inner	\$ 1.65	BY	65	C40Z-3358-A	Steering Idler Arm Bushing—Lower	1.45	B
63-65	C2AZ-2007-B	Brake Shoe Lining Kit—Front—H/D—Fade Resistant	8.80	A	65	C3DZ-3356-C	Steering Idler Arm Bushing—Upper	1.95	C
63-64	C3AZ-2007-C	Brake Shoe Lining Kit—Rear—H/D—Fade Resistant	8.95	A	63-65	C0AA-3590-D	Steering Sector Shaft Arm	21.55	CY
65	C5AZ-2007-B	Brake Shoe Lining Kit—Rear—Fade Resistant	8.80	A	65	C5AZ-4A022-A	Side Gear Spring Retainer—No Spin Diff.	3.70	C
FRONT SUSPENSION—STEERING—REAR AXLE					65	C5AZ-4A024-A	Side Gear Spring—No Spin Diff.	.65	C
65	C5AZ-3047-B	Front Suspension Upper Shaft Kit	6.25	C	63-65	C2AZ-4204-F	Differential Gear Case Assy.—Axle Models WCN-A, -B, -C	16.80	C
63-65	C4AZ-3048-A	Front Suspension Control Arm Mounting Kit	16.10	CX	63-64	C2AZ-4204-D	Differential Gear Case Assy.—Before 11-1-63	16.80	BX
65	C5AZ-3082-B	Front Suspension Upper Arm Assy.	6.00	C	64-65	C2AZ-4204-G	Differential Gear Case Assy.—Axle Models WCN-U, V—From 11-1-63	16.80	B
63-64	C0AZ-3102-A	Spindle Assy.—R.H.	70.15	CY	65	C5AZ-4204-A	Differential Gear Case Assy.—Large Bearings—No Spin Diff.	24.00	C
63-64	C0AZ-3103-A	Spindle Assy.—L.H.	70.15	CY	63-65	C2AZ-4209-J	Differential Gear and Pinion Kit—3.00 to 1	50.00	C
65	C5AZ-3105-C	Spindle Assy.—R.H.	70.15	C	63-65	C2AZ-4209-K	Differential Gear and Pinion Kit—3.50 to 1	50.00	B
65	C5AZ-3106-C	Spindle Assy.—L.H.	70.15	C	63-65	C2AZ-4209-L	Differential Gear and Pinion Kit—4.11 to 1	50.00	A
63-65	C0AA-3280-C	Spindle Connecting Rod Assy.	10.93	CY	63-65	C3UZ-4209-A	Differential Gear and Pinion Kit—4.57 to 1	50.00	B
63-65	51-3287	Clamp—Spindle Conn. Rod End	.53	C	64-65	C3AZ-4209-F	Differential Gear and Pinion Kit—4.44 to 1	50.00	CY
63-65	C1AA-3289-D	Spindle Connecting Rod End	9.78	CY	64-65	C4AZ-4209-A	Differential Gear and Pinion Kit—3.10 to 1—9" Ring Gear	125.00	CY
63-65	C0AA-3304-D	Steering Arm to Idler Arm Rod Assy.	19.88	CY	64-65	C4AZ-4209-B	Differential Gear and Pinion Kit—3.40 to 1—9" Ring Gear	125.00	CY
63-64	AG-3310-A	Drag Link Adjusting Sleeve	5.15	CY	64-65	C4AZ-4209-C	Differential Gear and Pinion Kit—4.33 to 1—9" Ring Gear	125.00	CY
65	C2VY-3310-A	Drag Link Adjusting Sleeve	2.00	B	64-65	C4AZ-4209-E	Differential Gear and Pinion Kit—4.71 to 1—9" Ring Gear	125.00	CY
63-64	C0AA-3351-A	Steering Idler Arm Mounting Bracket	5.15	CY					
65	C5AZ-3350-B	Steering Idler Arm and Mounting Bracket—4/S/T	5.15	CY					
65	C3DZ-3351-B	Steering Idler Arm Mounting Bracket—4/S/T	4.70	C					
63-65	C0AA-3355-A	Steering Idler Arm	9.10	CY					



FORD 427 ENGINE HIGH PERFORMANCE GENERAL PARTS LISTS (CONTINUED)

Year	Part Number	Description	Mfrs. Sugg. Retail Price	Class	Year	Part Number	Description	Mfrs. Sugg. Retail Price	Class
63-65	C4AZ-4209-F	Differential Gear and Pinion Kit—4.86 to 1—9" Ring Gear	125.00	CY	64	C1MM-5310-L	Front Spring—2600#—4/S/T	9.00	C
63-65	C4AZ-4209-G	Differential Gear and Pinion Kit—5.14 to 1—9" Ring Gear	125.00	CY	65	C5AZ-5310-AB	Front Spring—2130#—4/S/T	10.75	C
64-65	C4AZ-4209-H	Differential Gear and Pinion Kit—5.43 to 1—9" Ring Gear	125.00	CY	65	C5AZ-5310-AA	Front Spring—2030#—4/S/T	9.00	B
63-65	C4AZ-4209-J	Differential Gear and Pinion Kit—5.67 to 1—9" Ring Gear	125.00	CY	63-64	C1AA-5482-A	Stabilizer Assy.—Link Type	26.25	CY
63-65	C3AZ-4216-A	Differential Gear to Case Bolt	.69	B	63	C3AZ-5482-B	Stabilizer Assy.	26.25	CY
65	C5AZ-4A233-A	Driven Clutch—No Spin Diff.	19.90	C	65	C5AZ-5482-B	Stabilizer Assy.	10.65	C
63-64	C2SZ-4234-A	Rear Axle Shaft & Bearing Assy.—R.H.—Before 11-1-63	28.00	A	63-64	C0AA-5493-A	Stabilizer to Suspension Lower Arm Insulator—.94" I.D.	.87	BY
64-65	C3AZ-4234-A	Rear Axle Shaft & Bearing Assy.—Axle Models WCN-U, V—R.H.—From 11-1-63	55.00	A	65	C5AZ-5493-A	Stabilizer to Suspension Lower Arm Insulator—.72" I.D.	.49	B
63-64	C2SZ-4234-B	Rear Axle Shaft & Bearing Assy.—L.H.—Before 11-1-63	28.00	A	63	C3AZ-5493-A	Stabilizer to Suspension—Lower Arm Insulator—Lower	1.65	CY
64-65	C3AZ-4234-B	Rear Axle Shaft & Bearing Assy.—L.H.—From 11-1-63	55.00	C	ENGINE				
65	C5AZ-4234-C	Rear Axle Shaft & Bearing Assy. with 4/S/T—R.H.—Axle Models WDC-W, X	55.00	C	65	C5AE-6007H361J	Engine Assembly—8V—4/S/T	1193.00	L
65	C5AZ-4234-D	Rear Axle Shaft & Bearing Assy. with 4/S/T—L.H.—Axle Models WDC-W, X	55.00	C	(Includes: Carburetor, oil filter, oil pan, oil pump, water pump, distributor, spark plugs, ignition wiring and ignition coil, flywheel or clutch housing, clutch and flywheel, water connections and all covers. Does not include starter, generator, fuel pump, air cleaner, exhaust manifolds, fan or fan belts and breather tubes.)				
65	C5AZ-4588-A	Hold Out Ring—No Spin Diff.	6.50	C	63-65	C3AZ-6008-C	Complete Engine Overhaul Gasket Set	10.75	A
63	C3AZ-4602-R	Drive Shaft—Before 6-3-63—O/D	40.70	C	63	C3AZ-6009-K	Cylinder Assy.—4V—Mechanical Tappets—includes 306° Camshaft (less tappets)	517.00	A
63-64	C3AZ-4602-U	Drive Shaft—From 6-3-63—O/D	40.70	C	64	C3AZ-6009-V	Cylinder Assy.—4V—Mechanical Tappets—includes 306° Camshaft (less tappets)	517.00	A
63	C3AZ-4602-N	Drive Shaft—Before 6-3-63—3/S/T or 4/S/T	40.70	C	63-64	C3AZ-6009-Y	Cylinder Assy.—8V—Mechanical Tappets—includes 324° Camshaft (less tappets)	517.00	A
63-64	C3AZ-4602-V	Drive Shaft—From 6-3-63—3/S/T or 4/S/T	40.70	C	65	C3AZ-6009-Z	Cylinder Assy.—8V—Mechanical Tappets (less tappets)	517.00	A
65	C5AZ-4602-G	Drive Shaft—4/S/T—Before 11-16-64	40.70	B	63-64	C3AZ-6010-M	Cylinder Block Assy.	203.00	A
65	C5AZ-4602-M	Drive Shaft—4/S/T—From 11-16-64	40.70	B	65	C3AZ-6010-Z	Cylinder Block Assy.	203.00	A
64-65	TBAA-4616-A	Driving Pinion Bearing Cup—Rear—4V	2.28	A		C2AZ-6019-A	Cylinder Front Cover Kit	8.25	A
64-65	B7A-4616-A	Driving Pinion Bearing Cup—Front—4V	1.74	A		C0AE-6020-C	Cylinder Front Cover Gasket	.25	A
64-65	B7A-4621-A	Driving Pinion Bearing Cone & Roller Assy.	3.62	A	63-65	C3AZ-6C038-A	Engine Mount Heat Shield—R.H.	.50	C
64-65	TBAA-4621-A	Driving Pinion Bearing Cone & Roller Assy.—Front	4.48	BX	63-65	C3AZ-6C038-B	Engine Mount Heat Shield—L.H.	.50	C
63-65	C3AZ-4676-A	Driving Pinion Oil Seal Assy.—Axle Models WBT-BY, BZ, CA, WCN-U, V	3.65	CY	63	C3AZ-6049-G	Cylinder Head—Ident. marking #C3AE-6090-D (Before 3-15-63)	58.65	B
63	C2SZ-4851-C	Universal Joint Axle End Flange Assy.—4.11 ratio	8.75	A	63	C3AZ-6049-J	Cylinder Head—Ident. marking #C3AE-6090-G or C3AE-6090-H (From 3-15-63)	58.65	B
63-64	C3AZ-4851-G	Universal Joint Axle End Flange Assy.—Before 3-9-64	8.75	A	64-65	C3AZ-6049-K	Cylinder Head—Ident. marking #C3AE-6090-J	58.65	A
64-65	C4AZ-4851-A	Universal Joint Axle End Flange Assy.—From 3-3-64	17.50	B	63-65	C3AZ-6051-B	Cylinder Head Gasket—Steel	2.25	A
63-65	C3AZ-4851-H	Universal Joint Axle End Flange Assy. Extra Heavy Duty	13.75	CY	63-64	C3AZ-6068-C	Engine Rear Support Assy.	3.00	B
63-65	C3AZ-4880-A	Locking Differential Kit—No Spin Diff. with 31 Spline Axle Shaft	125.00	CA	65	C5AZ-6068-B	Engine Rear Support Assy.	3.00	B
FRONT SPRING AND STABILIZER					63-65	C3AZ-6079-B	Valve Grind Gasket Set	8.45	B
63	AJ-5310-R	Front Spring—2100#—4/S/T	22.62	CY	63-65	C3AZ-6108-F	Piston—Std. Red—4V	16.35	A
63-64	C0AA-5310-E	Front Spring—2425#—4/S/T—H/D	9.00	BX	63	C3AZ-6108-F	Piston—Std. Red—8V—(Before 5-1-63)	16.35	A
63-64	C3AZ-5310-D	Front Spring—2425#—4/S/T—Special High Rate	9.00	C	63-65	C3AZ-6108-F	Piston—Std. Red—8V—(From 5-1-63)	16.35	A
64	C0AA-5310-F	Front Spring—2325#—3 or 4/S/T—4V or 8V	9.00	A	63-65	C3AZ-6108-M	Piston—Std. Red—8V—(From 5-1-63)	16.35	A
64	C1MM-5310-K	Front Spring—2525#—4/S/T	9.00	C	63-65	C3AZ-6135-A	Piston Pin—Std. size	.95	C
					63-65	C3AZ-6140-B	Piston Pin Retainer	.07	C
					63-65	C3AZ-6148-A	Piston Ring Partial Set—Std.	7.40	A
					63-65	C3AZ-6200-F	Connecting Rod Assy.	7.35	A
					63-65	C1AE-6211-H	Connecting Rod Bearing—Std. Red	1.24	A
					63-65	C1AE-6211-J	Connecting Rod Bearing—Std. Blue	1.24	A



FORD 427 ENGINE HIGH PERFORMANCE GENERAL PARTS LISTS (CONTINUED)

Year	Part Number	Description	Mfrs. Sugg. Retail Price	Class	Year	Part Number	Description	Mfrs. Sugg. Retail Price	Class
63-65	C3AZ-6212-A	Connecting Rod Mat. 1 ³ / ₃₂ "—24	.16	B	63-64	B8A-6384-A	Flywheel Ring Gear	4.55	BX
63-65	C2AZ-6214-A	Connecting Rod Bolt—1 ³ / ₃₂ "—24x2.07" (before 9-15-64)	.36	C	65	C5AZ-6384-A	Flywheel Ring Gear	4.40	A
65	C2AZ-6124-B	Connecting Rod Bolt—1 ³ / ₃₂ "—24x2 ⁵ / ₃₂ " (from 9-15-64)	.36	C	65	C5AZ-6392-B	Flywheel Housing Assy.—Ident. C5AE-6394-A—8V	20.36	B
63-64	C3AZ-6250-D	Camshaft Assy.—Less Gear 4V—"VB" between last lobe & last journal (optional with C3AZ-6250-K)	34.15	A	63-64	C3AZ-6392-A	Flywheel Housing Assy.—Ident. C3AE-6394-A	20.36	B
63-65	C3AZ-6250-K	Camshaft Assy.—Less Gear—8V—Ident. "VB" & Yellow stripe	34.15	A	63-65	C3AZ-6435-B	Flywheel Housing Gasket	.90	C
63-65	C3AZ-6256-A	Camshaft Sprocket—Aluminum	4.93	A	63-65	C4AZ-6500-B	Mechanical Tappet Assy.	1.40	A
63-65	C3AZ-6261-A	Camshaft Bearing—Front—Std.	1.40	A	63	C0AE-6507-N	Intake Valve—Std.—use w/C3AZ-6049-D	1.53	A
63-65	B8A-6267-AA	Camshaft Bearing—Front Intermed.—Std.	1.40	A	63-65	C3AZ-6505-E	Exhaust Valve—Std.—use w/C3AZ-6049-D, C3AZ-6049-J & K Cyl. Hds.	7.54	A
63-65	B8A-6262-AA	Camshaft Bearing—Center—Std.	1.40	A	63-65	C3AZ-6507-J	Exhaust Valve—Bumper Head Type Std.—use w/C3AZ-6049-J & K	2.27	A
63-65	B8A-6270-AA	Camshaft Bearing—Rear Intermed.—Std.	1.40	A	63-65	C3AZ-6513-A	Valve Spring—2 Pc. design	1.50	A
63-65	B8A-6263-AA	Camshaft Bearing—Rear—Std.	1.40	A	63-65	C3AZ-6514-A	Valve Spring Retainer	.50	A
63-65	C3AZ-6265-A	Camshaft Sprocket Spacer	.25	B	63-65	B8A-6518-A	Valve Spring Retainer—.371"/.375" to .531"/.535" conical O.D.—Ident.—Marking Red	.16	A
63-65	B8A-6268-A	Timing Chain—48 Links	8.50	A	63-65	C1SE-6524-A	Valve Spring Oil Baffle	2.40	B
63-65	C3AZ-6269-A	Camshaft Thrust Plate	.96	B	63-65	C3AZ-6531-A	Valve Rocker Arm Shaft Support	1.50	B
63-65	C3AZ-6287-A	Camshaft Full Pump Drive Eccentric	2.20	A	63-65	C3AZ-6A536-A	Valve Spring Seat	.25	B
63-65	C4AZ-6303-H	Crankshaft	105.65	B	63-65	B6A-6549-C	Tappet and Rocker Arm Adjusting Screw—Std.	.27	A
63	B8A-6306-A	Crankshaft Sprocket—18 teeth—steel	3.20	A	63-65	C3AZ-6563-A	Valve Rocker Arm Shaft	4.25	A
64-65	C4AZ-6306-A	Crankshaft Sprocket—18 helical teeth	3.20	A	63-65	B8A-6564-B	Valve Rocker Arm and Screw Assy.	1.40	A
63-65	B8A-6310-A	Crankshaft Oil Slinger	.24	C	63-65	B8AZ-6565-C	Valve Push Rod	.92	A
63-64	C3AZ-6312-B	Crankshaft Pulley—Ident. marking C2AE-6316-B	26.30	C	63-65	B8AZ-6571-B	Valve Guide and Valve Stem Seal—Intake & Exhaust	.11	A
65	C3AZ-6312-F	Crankshaft Pulley—Ident. marking C4AE-6316-E	26.30	B	63-64	C3AZ-6582-D	Valve Rocker Arm Cover Assy.—Gold Metallic—R.H.	9.65	C
63-65	C1AZ-6A321-C	Crankshaft Rear Main Bearing Seal Kit	.97	A	63-64	C3AZ-6582-E	Valve Rocker Arm Cover Assy.—Gold Metallic—L.H.	4.25	B
63-65	C1AE-6333-A	Main Bearing—Front, Front Intermed., Rear Intermed., Rear—Std. Red—Upper & Lower	2.05	A	63-64	C3AZ-6582-F	Valve Rocker Arm Cover Assy.—Chrome—R.H.	9.65	B
63	C1AE-6337-A	Main Bearing—Center—Std. Red—Upper & Lower	4.27	A	63-64	C3AZ-6582-G	Valve Rocker Arm Cover Assy.—Chrome—L.H.	9.65	B
64-65	C4AZ-6337-A	Main Bearing—Center—Std. Red—Upper & Lower	3.40	A	65	C5AZ-6582-D	Valve Rocker Arm Cover Assy.—Chrome—R.H. & L.H.	9.65	C
63-65	C1AE-6333-B	Main Bearing—Front, Front Intermed., Rear Intermed., Rear—Std. Blue—Upper & Lower	2.05	A	63-65	B9AE-6584-C	Valve Rocker Arm Cover Gasket	.75	A
63	C1AE-6337-B	Main Bearing—Center—Std. Blue—Upper & Lower	4.27	A	63-65	C3AZ-6600-A	Oil Pump Assy.	16.55	A
64-65	C4AZ-6337-B	Main Bearing—Center—Std. Blue—Upper & Lower	3.40	B	63-65	C0AZ-6622-E	Oil Pump Screen, Tube and Cover Assy.	4.80	B
63-65	C1AE-6336-B	Crankshaft Rear Main Bearing Seal	.19	A	64-65	B8AZ-6626-A	Oil Pump Inlet Tube Fitting Gasket	.07	A
63-65	C1AE-6345-B	Crankshaft Main Bearing Cap Bolt	.39	C	63-64	C3AZ-6A630-A	Crankcase Ventilation Duct—4V	5.15	C
63-65	C3AZ-6A354-A	Crankshaft Main Bearing Cap Spacer—Red—.3765"/.3769"	.45	C	63-65	C3AZ-6A630-B	Crankcase Ventilation Duct—8V	5.15	C
63-65	C3AZ-6A354-B	Crankshaft Main Bearing Cap Spacer—Blue—.3748"/.3752"	.45	C	63-65	C0AE-6A631-A	Crankcase Vent. Oil Separator Element	.85	A
63-65	C3AZ-6A354-C	Crankshaft Main Bearing Cap Spacer—Yellow—.3731"/.3735"	.45	C	63-65	C1AE-6A632-A	Crankcase Vent. Oil Separator Gasket	.17	B
63-65	B8AZ-6359-A	Crankshaft Damper Spacer	1.45	A	63-65	C0AE-6A633-A	Crankcase Vent. Oil Separator Element Retainer	.96	C
63-65	C3AZ-6366-A	Flywheel Housing Cover	3.20	B	63-65	C0ME-6670-A	Cyl. Block Main Oil Galley Relief Valve Plunger Spring	.16	C
63-64	C3AZ-6375-E	Flywheel and Ring Gear Assy.—Ident. C3AE-6380-C	30.96	C	63-65	C1AE-6670-A	Oil Pump Body Relief Valve Spring	.16	C
65	C5AZ-6375-E	Flywheel and Ring Gear Assy.	30.96	B	63-65	B9AE-6674-B	Cyl. Block Main Oil Galley Relief Valve Plunger	.51	B
					63-65	C1AE-6674-A	Oil Pump Body Relief Valve Plunger	1.20	C
					63-64	C1AE-6675-F	Oil Pan Assy.	39.00	B



FORD 427 ENGINE HIGH PERFORMANCE GENERAL PARTS LISTS (CONTINUED)

Year	Part Number	Description	Mfrs. Sugg. Retail Price	Class	Year	Part Number	Description	Mfrs. Sugg. Retail Price	Class					
65	C1AZ-6675-F	Oil Pan Assy.	39.00	B	63-64	C3AZ-7B340-B	Transmission Third Speed Gear—W/4/S—29 helical teeth—36 clutch teeth	36.00	A					
63-65	COAL-6710-C	Oil Pan Gasket	.75	A	64	C3AZ-7B340-C	Transmission Third Speed Gear—27 Helical Teeth—36 Clutch Teeth—Close Ratio—W/4/S	44.50	CY					
63-65	C1AZ-6731-A	Oil Filter, Rotunda 6000 Mile Type	3.45	A	64-65	C4AZ-7B340-B	Transmission Third Speed Gear—F/4/S—25 helical teeth—36 clutch teeth	36.00	A					
63-65	C2OZ-6734-A	Oil Pan Drain Plug Gasket	.04	A	64-65	C4AZ-7285-A	3rd & 4th Shift Fork Cam and Shaft Lever—F/4/S	1.45	C					
63-64	C2AZ-6758-B	Crankcase Ventilation Tube Assy. with emission reduction control	1.35	C	64-65	C4AZ-7290-B	1st & 2nd Shift Fork Cam and Shaft Lever—F/4/S	.87	C					
63-64	C4AZ-6758-A	Crankcase Ventilation Tube Assy.—non-emission reduction	4.25	C	64-65	C4AZ-7290-A	Reverse Shift Fork Cam and Shaft Lever—F/4/S	.87	C					
65	C5AZ-6758-E	Crankcase Ventilation Tube Assy. non-emission reduction	4.25	C	64-65	C4AZ-70312-B	Reverse Gear Shift Lever—F/4/S	1.95	C					
64-65	C4AZ-6A827-A	Emission Reduction Flame Arrestor (closed system)	1.10	C	64	C3OZ-7326-E	3rd & 4th Speed Connecting Gear Shift Rod—W/4/S	3.15	C					
63-65	COAE-6881-A	Oil Filter Adapter & Insert Assy.—Except with engine warning system	3.05	A	64	C4AZ-7400-B	Gear Shift Control Assy.—F/4/S	26.75	C					
63-65	C3AZ-6881-A	Oil Filter Adapter & Insert Assy.	3.05	C	64	C4AZ-7515-A	Clutch Release Lever Assy.—F/4/S	2.10	C					
TRANSMISSION—CLUTCH														
63-64	C4AZ-7003-N	Transmission and Extension Assy.—Production Ident. "C4AR-N"—4V & 6V—4 speed	387.30	C	63-64	C3AZ-7515-B	Clutch Release Lever Assy.—W/4/S	2.10	B					
65	C5AZ-7003-G	Transmission and Extension Assy.—Production Ident. "HEH-R"—4 spd.	387.30	C	63-65	C3AZ-7521-D	Clutch Pedal Release Assy.—S/T	1.30	C					
63	C3AZ-7006-C	Transmission Case—S/T	23.95	C	63-64	C3AZ-7523-B	Retracting Spring—Clutch Release—11.42"—34½ coils	.85	C					
63-65	C3AZ-7007-B	Engine Rear Plate Assy.—S/T & O/D	3.15	C	63-64	C3AZ-7523-C	Retracting Spring—Clutch Release—11.28"—23½ coils	.85	C					
64	C3AZ-7009-A	Transmission Gears Kit—Close Ratio	164.60	CY	65	C5AZ-7523-B	Retracting Spring Clutch Release—F/4/S	.85	C					
64-65	C4AZ-7017-H	Transmission Input Shaft—F/4/S	34.95	A	63-64	C3AZ-7528-G	Clutch Release Equalizer Bar—4/S/T	5.55	B					
63-64	C3AZ-7017-G	Transmission Input Shaft—W/4/S	45.75	A	63-65	C3AZ-7B529-A	Clutch Release Lever Retracting Spring Bracket Assy.—F & W/4/S	.40	C					
63	51A-7025	Transmission Input Shaft Bearing—S/T	7.14	A	65	C5AZ-7B539-A	Clutch Release Idler Lever Adjusting Spacer—F/4/S	.25	C					
64-65	8D-7025	Transmission Input Shaft Bearing—F/4/S	10.05	A	65	C5AZ-7542-A	Clutch Retracting Spring Bracket—F/4/S	.61	C					
63-65	8D-7065	Transmission Output Shaft Bearing—4/S/T	7.02	A	63	C3AZ-7550-M	Clutch Disc—F & W/4/S	35.50	V					
63-65	C3AZ-7029-A	Reverse Idler Gen. Rear Thrust Washer S/T	.30	A	63	C3AZ-7563-C	Clutch Pressure Plate—F & W/4/S	30.45	V					
64	C4AZ-7A039-B	Extension Housing F/4/S	27.35	C	63	C3AZ-7550-N	Clutch Disc—8V—solid type—W/4/S	53.20	C					
64	C4AZ-7050-B	Input Shaft Bearing Retainer—F/4/S	5.95	C	63	C3AZ-7563-D	Clutch Pressure Plate—8V—solid type—W/4/S	52.60	CY					
65	C5AZ-7050-B	Input Shaft Bearing Retainer—F/4/S	5.95	C	64-65	C4AZ-7550-A	Clutch Disc—F & W/4/S	35.50	V					
64-65	C4AZ-7061-D	Output Shaft—F/4/S	43.40	A	64-65	C3AZ-7563-C	Clutch Pressure Plate—F & W/4/S	30.45	V					
63-64	C3AZ-7102-E	Transmission Second Speed Gear—W/4/S—30 helical teeth	44.50	A	64	C3AZ-7507-D	Clutch Release Equalizer to Frame Bracket—W/4/S	.44	C					
64-65	C4AZ-7102-D	Transmission Second Speed Gear—F/4/S—28 Helical Teeth	21.25	A	64-65	C4AZ-7561-A	Clutch Release Bearing Hub Assy.—F/4/S	3.75	B					
64	C3AZ-7102-G	Transmission Second Speed Gear—W/4/S—29 helical teeth	44.50	CY	64-65	COTZ-7580-A	Clutch Release Bearing Assy.—F/4/S	4.15	A					
63-64	C3AZ-7113-H	Countershaft Cluster Gear—W/4/S—29-23-19-17 teeth	75.65	A	63-65	B8A-7600-A	Clutch Pilot Bearing	1.50	A					
64	C3AZ-7113-K	Countershaft Cluster Gear—W/4/S—29-25-20-17 teeth	74.10	CY	COOLING AND GRILLE									
64-65	C4AZ-7113-A	Countershaft Cluster Gear—F/4/S—25-21-18-15 teeth	34.75	A	63	C3AZ-8005-B	Radiator Assy.	61.88	A					
64	C4AZ-7210-E	Floor Gear Shift Lever—F/4/S	26.80	B	65	C5AZ-8005-B	Radiator Assy. 1.95" core thickness	61.88	A					
65	C5AZ-7210-D	Floor Gear Shift Lever—F/4/S	5.30	B	62-64	C1AZ-8A080-B	Radiator Tank Assy.	15.85	A					
64-65	C3TZ-7A283-B	Input Shaft Oil Seal—F/4/S	.95	B	62-63	C2RZ-8260-J	Radiator Hose	2.50	A					
64	C3AZ-7B340-C	Transmission Third Speed Gear—W/4/S—27 helical teeth—36 clutch teeth (close ratio)	44.50	CY	64	C4AZ-8260-A	Radiator Hose	1.75	A					
					65	C5AZ-8260-B	Radiator Hose	2.00	A					
					61-63	C2AZ-8501-B	Water Pump Assy.	24.00	A					



FORD 427 ENGINE HIGH PERFORMANCE GENERAL PARTS LISTS (CONTINUED)

Year	Part Number	Description	Mfrs. Sugg. Retail Price	Class	Year	Part Number	Description	Mfrs. Sugg. Retail Price	Class
65	C5AZ-8501-D	Water Pump Assy.	24.00	C	63-64	C3AZ-9431-F	Exhaust Manifold—L.H.	34.50	C
62-65	B7A-8509-B	Water Pump Pulley	2.45	A	65	C5AZ-9431-C	Exhaust Manifold—8V—L.H.	42.95	C
62-65	C2AZ-8513-A	Water Pump Backing Plate Gasket	.30	B	63-65	C3AZ-9433-A	Intake Manifold Gasket & Seal Set	2.00	A
60-65	C0AE-8555-A	Water By-Pass Tube	.36	A	63	C0AE-9A435-B	Exhaust Manifold to Muffler Inlet Pipe Spacer	3.67	C
63-65	C2RZ-8575-A	Water Thermostat 160°	3.25	A	63-65	C2AZ-9441-A	Intake Manifold to Cyl. Head Gasket	.75	A
65	C5AZ-8575-A	Water Thermostat 192°/195°	3.25	A	63-65	C3AZ-9441-B	Intake Manifold to Cyl. Head Gasket—Heat Blocked	1.00	A
65	C5AZ-8592-B	Cylinder Head Water Outlet Connection Assy.	4.50	B	63-65	C2AZ-9447-E	Carburetor to Intake Manifold Gasket—8V	.21	A
63	C2AZ-8600-A	5 Blade Fan Assy.—2 3/8" ctr. hole	10.65	A	63-64	C3AZ-9447-A	Carburetor to Intake Manifold Gasket—4V	.21	C
63-64	C1MZ-8600-D	6 Blade Fan Assy.—5/8" ctr. hole	10.65	A	63-65	C3AZ-9A447-A	Exhaust Manifold Mounting Bolt Locking Tab	.13	C
63	C3AZ-8A611-C	Fan Guard 22.50" long—Chrome	8.90	C	63-65	C0AA-9450-A	Exhaust Manifold to Exhaust Pipe Gasket	.42	A
64	C4AZ-8A611-A	Fan Guard 12" long	2.20	A	63-65	C3AZ-9A501-A	Carburetor Secondary Balance Tube—8V	.40	C
64	C4AZ-8A611-B	Fan Guard—Chrome	3.90	C	63-64	C3AZ-9510-K	Carburetor 4V (Tag Ident. C3AE-B)	79.45	C
63	C2AZ-8A616-A	Fan Clutch Assy.	22.30	BX	63-64	C3AZ-9510-S	Carburetor 8V (Tag Ident. C3AE-C)	79.45	C
63-64	C3MY-8620-A	43" Fan Belt	3.25	C	64-65	C4AZ-9510-A	Carburetor 8V (Tag Ident. C3AF-BK-BJ)	79.45	C
65	C2AZ-8620-L	Fan Belt—(Before 1-4-65)	3.25	B	63-65	C3AZ-9A589-C	Carb. to Intake Manifold Spacer—4V (with emission reduction)	2.50	C
65	C2AZ-8620-M	Fan Belt—(From 1-4-65)	3.25	B	63-64	C3AZ-9502-D	Gasket Set—for Carb. C3AZ-9510-K	2.75	C
FUEL SYSTEM									
63-65	B7Q-9155-A	Fuel Filter Assy.—4V, 6V, 8V	5.35	A	63-64	C3AZ-9590-E	Repair Kit—for Carb. C3AZ-9510-K	12.65	C
63-65	C0AE-9180-A	Fuel Filter Bracket—4V, 6V, 8V	2.05	C	63-65	C1AZ-9502-B	Gasket Set—for Carb. C3AZ-9510-L, S & C4AZ-9510-A	2.70	A
63-65	C3AZ-9D280-A	Carburetor Fuel Tube Assy.—8V	14.00	C	63-64	58MK-9590-K	Repair Kit—for Carb. C3AZ-9510-L, S	12.55	C
63-65	C3AZ-9D281-A	Carburetor Fuel Hose—Rear	.59	C	64-65	C1AZ-9590-G	Repair Kit—for Carb. C4AZ-9510-A	13.10	B
63-64	C3AZ-9E295-A	Oil Temp. Indicator Wiring Assy.	8.25	C	63	C3AZ-9600-C	Air Cleaner Assy. 4V—(Identified C3AF-9600-D)	22.65	C
63-64	C3AZ-9E296-A	Oil Temp. Indicator Flasher Assy.	2.60	C	63-64	C4AZ-9600-D	Air Cleaner Assy.—chrome—4V (except with closed emission system)—(Identified C4AF-9600-D)	26.10	C
65	C3SZ-9324-B	Fuel Tube Connector Hose—67.75" long	.90	C	63-64	C3AZ-9600-G	Air Cleaner Assy.—Polished Alum.—8V (except with closed emission system) (Identified C3AE-9600-A, C4MF-9600-E)	41.25	C
65	C3SZ-9324-C	Fuel Tube Connector Hose—70.25" long	.90	C	64	C4AZ-9600-AZ	Air Cleaner Assy.—Chrome—4V (closed emission system) (identified C5AF-9600-R, C4AF-9600-AY)	22.65	C
63-64	C0AZ-9349-A	Fuel Pump Repair Kit (for C0AE-9350-E)	5.10	C	64	C3AZ-9600-L	Air Cleaner Assy.—8V (closed emission system)—(identified C4AF-9600-AT)	41.25	C
63-65	C0AZ-9349-B	Fuel Pump Repair Kit (for C0AZ-9350-A)	5.25	C	65	C5MY-9600-A	Air Cleaner Assy.—8V—(identified C5MF-9600-G, C5AF-9600-V, y)	41.25	C
63-65	C0AZ-9350-A	Fuel Pump Assy. (Before 10-15-64)	17.00	A	63-64	C0AE-9601-C	Air Cleaner Element—4V (used with C3AZ-9600-C, C4AZ-9600-D, AZ)	6.90	A
65	C0AZ-9350-C	Fuel Pump Assy. (From 10-15-64)	17.00	A	63-64	C3AZ-9601-C	Air Cleaner Element—8V (used with C3AZ-9600-G, L)	11.25	B
63-65	C4AZ-9365-A	Fuel Filter Element Assy.	.97	A	65	C3AZ-9601-D	Air Cleaner Element—8V (used with C5MY-9600-A)	11.25	B
63-64	C3AZ-9424-J	Intake Manifold—4V	134.80	C	63-64	C3AZ-9654-A	Air Cleaner to Carb. Gasket—4V—.06" thick	.25	C
63-64	C3AZ-9424-L	Intake Manifold—8V (Before 1-2-64)	147.15	C	63	C3AZ-9654-C	Air Cleaner to Carb. Gasket—4V & 8V—.188" thick	.25	C
64	C3AZ-9424-M	Intake Manifold—8V (From 1-2-64) (non-emission reduction)	147.15	C	63-65	C3AZ-9C654-A	Ram Air Intake Kit—Drag Strip High Performance—8V	123.10	CY
65	C5AZ-9424-C	Intake Manifold—8V	34.50	B					
63-65	C3AZ-9A424-A	Intake Manifold to Cyl. Block Seal—Rear	.25	A					
63-65	C3AZ-9A425-A	Intake Manifold to Cyl. Block Seal—Front	.25	A					
63	C0AE-9A427-B	Exhaust Thermostat Control Valve Assy.—(Before 11-22-62)	13.25	A					
63-65	C3AZ-9A427-A	Exhaust Thermostat Control Valve Assy.—(From 11-22-62)	13.25	B					
63-64	C3AZ-9430-C	Exhaust Manifold—R.H.	34.50	C					
65	C5AZ-9430-C	Exhaust Manifold—8V—R.H.	42.95	C					



FORD 427 ENGINE HIGH PERFORMANCE GENERAL PARTS LISTS (CONTINUED)

Year	Part Number	Description	Mfrs. Sugg. Retail Price	Class	Year	Part Number	Description	Mfrs. Sugg. Retail Price	Class
64	C4AZ-9725-B	Accelerator Assy.	3.65	C	65	C5AZ-12127-E	Distributor Assy. †C5AF-12127-E—use with transistorized ignition	41.50	C
65	C5AZ-9728-D	Accelerator Shaft Bracket	.42	C	65	C5AZ-12127-F	Distributor Assy.—†C5AF-12127-F—(use with transistorized ignition)	41.50	C
63-64	C3AZ-9732-C	Accelerator Bellcrank	9.75	C	63-65	C0AF-12152-A	Distributor Breaker Plate Assy.	2.45	B
65	C5AZ-9732-A	Accelerator Bellcrank	9.75	A	63-65	C3AZ-12171-A	Distributor Breaker Contact Point—use with C3AZ-12127-AF, C5AZ-12127-F Set Assy.—(use with transistorized ignition)	2.95	A
65	C5AZ-9737-E	Accelerator Retracting Spring	.31	C	63-65	FDS-12171-A	Distributor Breaker Contact Point Set Assy.—use with C5AZ-12127-E	2.95	A
65	C5AZ-9A758-D	Accelerator Pedal to Carb. Throttle Control Cable Assy.—8V—(Before 2-15-65)	4.10	C	63-64	C2TZ-12188-A	Distributor Weight Assy.—use with C3AZ-12127-AE	1.40	A
65	C5AZ-9A758-L	Accelerator Pedal to Carb. Throttle Control Cable Assy.—8V—(From 2-15-65)	4.10	C	63-65	C5AZ-12188-A	Distributor Weight Assy.—use with C5AZ-12127-E, C5AZ-12127-F	.87	A
63-65	C3AZ-9C760-A	Carb. Throttle Lever Trunnion—8V	1.35	C	63-64	B7A-12191-B	Distributor Weight Spring—Secondary—use with C3AZ-12127-AE, C3AZ-12127-AF	.44	B
63-65	PB8M-9767-B	Carb. Throttle Synchro. Rod End—8V	1.65	C	60-64	B8QH-12192-C	Distributor Weight Spring—Primary—use with C3AZ-12127-AE, C3AZ-12127-AF	.18	B
65	C3AZ-9819-D	Thermostatic Choke Control Outlet Tube—8V (From 9-11-64)	2.30	C	63-65	C5AZ-12192-D	Distributor Weight Spring—Primary—use with C5AZ-12127-E, C5AZ-12127-F	.35	C
63-65	C3AZ-9819-B	Thermostatic Choke Control Outlet Tube—8V (Before 9-11-64)	2.30	C	63-65	C5AZ-12192-A	Distributor Weight Spring—Secondary—use with C5AZ-12127-E, C5AZ-12127-F	.25	B
63-64	C3AZ-9819-A	Thermostatic Choke Control Outlet Tube—4V	.90	C	63-64	C3AZ-12210-C	Distributor Cam Assy.—use with C3AZ-12127-AE, C3AZ-12127-AF	6.00	C
63-65	C3AZ-9B841-A	Carb. Throttle Rod—Front (Bright Finish—8V)	4.35	C	63-65	C5AZ-12210-B	Distributor Cam Assy.—use with C5AZ-12127-E, C5AZ-12127-F	6.00	C
63-65	C3AZ-9B842-B	Carb. Throttle Rod—Rear—8V	4.35	C	63-65	C0AF-12216-B	Distributor Primary Terminal Wire Assy.—use with C3AZ-12127-AE, C5AZ-12127-E	.45	C
GENERATOR, STARTER, DISTRIBUTOR					63-65	C3AZ-12216-A	Distributor Primary Terminal Wire Assy.—use with C3AZ-12127-AF, C5AZ-12127-F (use with transistorized ignition)	.40	C
63	C3TZ-10505-B	Generator Voltage Regulator	8.65	A	63-65	C3AZ-12239-A	Distributor Breaker Cover Assy.—use with C3AZ-12127-AF, C5AZ-12127-F (use with transistorized ignition)	.90	C
62-63	FAP-10130-A	Generator Pulley 4V, 6V, 8V	4.15	A	63-65	C3AZ-12250-A	Wiring Circuit Breaker Assy. 4V or 8V (use with transistorized ignition)	2.00	C
63-65	C3SZ-10316-B	Alternator Voltage Regulator	13.45	A	63-64	C3AZ-12259-J	Spark Plug Wire Set—(Linen Core)	8.10	A
63-64	C3MY-10344-A	Alternator Pulley	3.00	C	63-64	C3AZ-12259-F	Spark Plug Wire Set (Steel Core)	9.00	A
63-64	C3MY-10346-A	Alternator Assy.	59.80	C	65	C5AZ-12259-C	Spark Plug Wire Set—(Steel Core)	9.00	C
63-64	C1TF-10B840-A	Oil Temp. Indicator Warning Lamp Relay	3.05	CX	65	C5AZ-12259-D	Spark Plug Wire Set—(Rayon Core)	8.10	C
63-64	C3AZ-10B921-A	Oil Temp. Warning Switch-On Oil Filter Adapter	4.10	C	63-64	C3AZ-12298-A	Ignition Coil to Distributor High Tension Wiring Assy.	.83	C
65	C3AZ-10B921-B	Oil Temp. Warning Switch-On Oil Filter Adapter	4.10	C	65	B8QH-12298-A	Ignition Coil to Distributor High Tension Wiring Assy. 8V (Steel Core)	.83	A
65	C3OZ-11002-C	Starter Assy.	45.25	A	65	C4AZ-12298-C	Ignition Coil to Distributor High Tension Wiring Assy.	.83	A
63-65	C3TZ-12A027-A	Ignition Current Amplifier Assy. 4V or 8V	70.00	B	63-64	7RA-12300-C	Distributor Condenser Assy.—use with C3AZ-12127-AE	.93	A
65	C3TZ-12A027-B	Ignition Current Amplifier Assy. 8V—use with transistor ignition	70.00	A	63-65	B9AF-12300-A	Distributor Condenser Assy.—use with C5AZ-12127-E	.93	A
63-65	C3TZ-12029-A	Ignition Coil Assy.—Less Mounting Strap 12V—(use with transistorized ignition)	9.50	B	†Identification Number stamped on Distributor Housing.				
63	C3TZ-12A042-A	Ignition Current Amplifier Relay 4V or 8V (use with transistorized ignition)	2.80	C	SPEEDOMETER				
64-65	C3TZ-12A042-B	Ignition Current Amplifier Relay 4V or 8V (use with transistorized ignition)	2.80	B	63	C2AZ-17285-A	Speedometer Driving Gear—4/S/T 7 teeth—Steel	3.70	B
63-65	C3TZ-12A046-A	Ignition Bailout Resistor & Bracket Assy.—(use with transistorized ignition)	4.10	B					
63-64	C3TZ-12A055-A	Distributor Cam Lubricator—use with C3AZ-12127-AE, C3AZ-12127-AF	.10	C					
65	C5AZ-12A072-B	Ignition Curb Amplifier—Bracket—(use with transistorized ignition)	1.00	C					
64	A9AZ-12113-A	Wire Terminal Weather Seal	.11	A					
63-64	C3AZ-12127-AE	Distributor Assy.—†C3AF-12127-AE—replaced by C5AZ-12127-E	17.00	C					
63-64	C3AZ-12127-AF	Distributor Assy.—†C3AF-12127-AF—Replaced by C5AZ-12127-F	17.00	C					



FORD 427 ENGINE HIGH PERFORMANCE GENERAL PARTS LISTS (CONTINUED)

Year	Part Number	Description	Mfrs. Sugg. Retail Price	Class	Year	Part Number	Description	Mfrs. Sugg. Retail Price	Class
64-65	B7C-17285-A	Speedometer Driving Gear—4/S/T 6 teeth	3.95	A	SHOCK ABSORBERS				
65	C0DD-17271-C	Driven Gear Assy.—4.11 Axle Ratio 7.35x15, 7.75x15 tires—19 teeth—O/D 3/S/T, 4/S/T	.95	A	63-64	C4MY-18124-A	Front Shock Absorber Kit—H/D	9.80	A
65	C0DD-17271-B	Driven Gear Assy.—4.11 Axle Ratio—8.15x15 tires—18 teeth—O/D, 3/S/T, 4/S/T	.95	A	63-64	C4AZ-18125-E	Rear Shock Absorber Kit—H/D	9.80	A
					65	C5AZ-18124-B	Front Shock Absorber Kit—H/D	9.80	A
					65	C5AZ-18125-B	Rear Shock Absorber Kit—H/D	9.80	A



FORD 352, 390 AND 406 HIGH PERFORMANCE ENGINES GENERAL PARTS LIST

Year	Part Number	Description	Mfrs. Sugg. Retail Price	Class	Year	Part Number	Description	Mfrs. Sugg. Retail Price	Class
WHEELS AND BRAKES					60-63	WAB-4209-K	Differential Gear and Pinion Kit 3.40 to 1 (352 and 390 engines)	125.00	CY
61-63	C1AA-1177-A	Seal—Rear Wheel Bearing Oil—Inner	1.65	BY	60-63	C4AZ-4209-F	Differential Gear and Pinion Kit—4.86 to 1—9" Ring Gear	125.00	CY
60	B7Y-1190-A	Retainer—Front Wheel Grease	1.75	A	60-63	C4AZ-4209-G	Differential Gear and Pinion Kit—5.14 to 1—9" Ring Gear	125.00	CY
60	AA-1216-A	Cone & Roller Assy.—Front Wheel Outer Bearing	3.08	A	60-63	C4AZ-4209-J	Differential Gear and Pinion Kit—5.67 to 1—9" Ring Gear	125.00	CY
61-63	C2AZ-2007-B	Brake Shoe Lining Kit—Front—H/D Fade Resistant	8.80	A	60	B7A-4211-A	Differential Pinion Shaft (352 eng.)	1.95	A
61-63	C3AZ-2007-C	Brake Shoe Lining Kit—Rear—H/D—Fade Resistant	8.95	A	60	B7A-4215-B	Differential Shaft Pinion Kit (352 eng.)	5.93	A
FRONT SUSPENSION—STEERING—REAR AXLE					62-63	C3AZ-4216-A	Differential Gear to Case Bolt (406 eng.)	.69	B
60-63	C0AZ-3102-A	Spindle Assy.—R.H.	70.15	CY	60-62	B7A-4221-A	Differential Bearing Cone & Roller Assy. (352 and 390 engines)	3.40	A
60-63	C0AZ-3103-A	Spindle Assy.—L.H.	70.15	CY	61-62	B7A-4221-B	Differential Bearing Cone & Roller Assy. (390 and 406 engines)	3.85	A
60-63	C0AA-3280-C	Spindle Connecting Rod Assy.	10.93	CY	60	B7A-4222-A	Differential Bearing Cup (352 eng.)	1.82	A
60-63	51-3287	Clamp—Spindle Conn. Rod End	.53	C	61-62	B7A-4222-B	Differential Bearing Cup (390 and 406 eng.)	2.00	A
60-63	C1AA-3289-D	Spindle Connecting Rod End	9.78	CY	60-62	C0AW-4234-D	Rear Axle Shaft & Bearing Assy.—R.H. (352 and 390 engines)	30.80	A
60-63	C0AA-3304-D	Steering Arm to Idler Arm Rod Assy.	19.88	CY	60-62	C0AZ-4235-C	Rear Axle Shaft & Bearing Assy.—L.H. (352 and 390 engines)	120.00	CY
60-63	AG-3310-A	Drag Link Adjusting Sleeve	5.15	CY	62-63	C2SZ-4234-A	Rear Axle Shaft & Bearing Assy.—R.H. (406 eng.)	28.00	A
60-63	C0AA-3351-A	Steering Idler Arm Mounting Bracket	5.15	CY	62-63	C2SZ-4234-B	Rear Axle Shaft & Bearing Assy.—L.H. (406 eng.)	28.00	A
60-63	C0AA-3355-A	Steering Idler Arm	9.10	CY	60	B7A-4236-B	Differential Side Gear Kit (352 4V eng.)	13.35	A
60-63	LF-3357-A	Steering Idler Arm Bushing	1.00	CY	60	C0AA-4602-J	Drive Shaft—352—4V—O/D & C/M	65.55	CY
60-63	C0AA-3590-D	Steering Sector Shaft Arm	21.55	CY	60	C0AA-4602-K	Drive Shaft—352—4V—S/T	65.55	CY
60	C0AW-4204-A	Differential Gear Case Assy. (352 eng.)	47.81	C	61-62	C1AA-4602-L	Drive Shaft—390 4V and 6V—S/T	40.70	B
62-63	C2AZ-4204-F	Differential Gear Case Assy.—Axle Models WCN-A, -B, -C (406 eng.)	16.80	C	62	C2AZ-4602-E	Drive Shaft—390 and 406—3 or 4/S/T	40.70	A
62-63	C2AZ-4204-D	Differential Gear Case Assy.—Use when WAB-4209 gears are used (406 eng.)	16.80	BX	61-62	C2AZ-4602-H	Drive Shaft—352, 390 and 406 O/D; 390 C/M, 390 4V and 6V All	40.70	B
62-63	C2AZ-4209-J	Differential Gear and Pinion Kit 3.00 to 1 (406 eng.)	50.00	C	63	C3AZ-4602-B	Drive Shaft—390 and 406 engines 3 or 4/S/T (Before 6-17-63)	40.70	A
62-63	C2AZ-4209-K	Differential Gear and Pinion Kit 3.50 to 1 (406 eng.)	50.00	B	63-64	C3AZ-4602-S	Drive Shaft—390 4V—3 or 4/S/T (From 6-17-63)	40.70	A
62-63	C2AZ-4209-L	Differential Gear and Pinion Kit 4.11 to 1 (406 eng.)	50.00	A	60-63	C3AZ-4676-A	Driving Pinion Oil Seal Assy.	3.65	CY
60-63	WAB-4209-D	Differential Gear and Pinion Kit 5.43 to 1 (352 and 390 engines)	125.00	CY	61-63	C3AZ-4851-A	Universal Joint Axle End Flange Assy. (406 eng.)	8.75	A
60-63	WAB-4209-E	Differential Gear and Pinion Kit 5.14 to 1 (352 and 390 engines)	125.00	CY	60-61	C0AW-4953-A	Differential Kit—Less Driven Gear 4V—1960 352 eng. & 1961 390 eng. S/T & O/D	110.53	C
60-63	WAB-4209-J	Differential Gear and Pinion Kit 4.29 to 1 (352 and 390 engines)	125.00	CY					



FORD 352, 390 AND 406 HIGH PERFORMANCE ENGINES GENERAL PARTS LIST (CONTINUED)

Year	Part Number	Description	Mfrs. Sugg. Retail Price	Class	Year	Part Number	Description	Mfrs. Sugg. Retail Price	Class
FRONT SPRING AND STABILIZER					60-63	C1AE-6211-H	Connecting Rod Bearing—Std. Red 352, 390, 406	1.24	A
60-63	AJ-5310-R	Front Spring—2100#—352, 390, 406 eng.	22.62	CY	60-63	C1AE-6211-J	Connecting Rod Bearing—Std. Blue—352, 390, 406	1.24	A
62	C2AZ-5310-A	Front Spring—2425#—3 or 4/S/T—390, 406 eng.	22.62	CY	61-63	C2AZ-6214-A	Connecting Rod Bolt—390, 406—13/32"—24 x 2.07"	.36	C
62	C2AZ-5310-B	Front Spring—2500#—4/S/T—352, 390, 406 eng.	9.00	B	60	C1AE-6214-A	Connecting Rod Bolt—352—3/8"—24x2.10"	.36	A
63	C0AA-5310-E	Front Spring—2425#—H/D 4/S/T—352, 390, 406 eng.	9.00	BX	60-62	C2AZ-6250-A	Camshaft Assy.—Less Gear—352, 390, 406 Cast Letter Ident. "K" & stamped letter "A"	34.15	A
63	C3AZ-5310-A	Front Spring—2425#—4/S/T—352, 390, 406 eng.	9.00	B	63	C3AZ-6250-D	Camshaft Assy.—Less Gear—406—"VB" between last lobe & last journal	34.15	A
63	C3AZ-5310-D	Front Spring—2425#—4/S/T—Special High Rate—352, 390 eng.	9.00	C	62	B8A-6256-A	Camshaft Sprocket—Cast Iron—390, 406	4.93	A
60-63	C1AA-5482-A	Stabilizer Assy.—Link Type	26.25	CY	63	C3AZ-6256-A	Camshaft Sprocket—Alum.—406	4.93	A
60-63	C0AA-5493-A	Stabilizer to Suspension—Lower Arm Insulator,—.94" I.D. (Gold)	.87	BY	63	C3AZ-6261-A	Camshaft Bearing—Front Std.—406	1.40	A
ENGINE					60-63	B8A-6267-AA	Camshaft Bearing—Front Intermed. Std. 352, 390, 406	1.40	A
62-63	C2AZ-6008-B	Complete Engine Overhaul Gasket Set 406 eng.	11.95	C	60-63	B8A-6262-AA	Camshaft Bearing—Center—Std.—352, 390, 406	1.40	A
60	C0AE-6009-G	Cylinder Assy.—352 (less tappets)	642.00	C	60-63	B8A-6263-AA	Camshaft Bearing—Rear—Std.—352, 390, 406	1.40	A
61-62	C2AZ-6009-D	Cylinder Assy.—390 Mechanical Tappets (less tappets)	517.00	AA	60-62	B8A-6261-AA	Camshaft Bearing—Front—Std.—352, 390, 406	1.40	A
62-63	C3AZ-6009-B	Cylinder Assy.—Mechanical Tappets 406 eng. (less tappets)	517.00	A	61-62	B8A-6267-AA	Camshaft Bearing—Front Intermed.—Std. 390, 406	14.0	A
60	C0AZ-6010-B	Cylinder Block Assy.—352 eng.	203.00	C	60-63	B8A-6270-AA	Camshaft Bearing—Rear Intermed.—Std. 352, 390, 406	1.40	A
61-62	C2AZ-6010-B	Cylinder Block Assy.—390	203.00	A	60-63	B8A-6268-A	Timing Chain—48 Links—352, 390, 406	8.50	A
62-63	C3AZ-6010-E	Cylinder Block Assy.—406	203.00	A	62-63	C3AZ-6287-A	Camshaft Fuel Pump Drive Eccentric—406	2.20	A
60-62	C0AE-6049-C	Cylinder Head—352 & 390	50.80	A	60	C0AE-6303-D	Crankshaft—352	105.65	C
62-63	C3AZ-6049-H	Cylinder Head—406	58.65	A	61-63	C3AZ-6303-C	Crankshaft—390, 406 (oil grooves on all main bearing journals)	3.20	A
60-65	B9AE-6051-A	Cylinder Head Gasket—352 & 390—Steel	1.05	A	60-63	B8A-6306-A	Crankshaft Sprocket—18 teeth—Steel—352, 390, 406	3.20	A
62-63	C2AZ-6051-A	Cylinder Head Gasket—406—Steel	2.25	A	60-63	B8A-6310-A	Crankshaft Oil Slinger—352, 390, 406	.24	C
60-62	C0AA-6054-A	Engine Rear Support Retainer—352, 390, 406	.60	B	60-63	C1AZ-6312-A	Crankshaft Pulley—352, 390, 406	18.15	B
63	C3AZ-6054-A	Engine Rear Support Retainer—406	.60	B	60-63	C1AZ-6A321-C	Crankshaft Rear Main Bearing Seal Kit—352, 390, 406	.97	A
61-65	C1AE-6065-A	Cylinder Head Bolt—352, 390, 406	.28	B	60	C4TZ-6333-A	Main Bearing—Front, Front Intermed., Rear Intermed., Rear—Std. Red—Upper & Lower—352	2.05	A
60-62	C1AA-6068-A	Engine Rear Support Assy.—352, 390, 406	1.85	A	60	C4TZ-6337-A	Main Bearing—Center—Std. Red—Upper & Lower—352	3.40	A
63	C3AZ-6068-C	Engine Rear Support Assy. 406	3.00	B	60	C4TZ-6333-B	Main Bearing—Front, Front Intermed., Rear Intermed., Rear—Std. Blue—Upper & Lower—352	2.05	A
62-63	C2AZ-6079-B	Valve Grind Gasket Set—406	7.25	A	61-63	C1AE-6333-A	Main Bearing—Front, Front Intermed., Rear Intermed., Rear—Std. Red—Upper & Lower—390, 406	2.05	A
60	C0AE-6108-AJ	Piston—Std.—Blue—352	16.34	C	61-63	C1AE-6337-A	Main Bearing—Center—Std. Red—Upper & Lower—390, 406	4.27	A
61-62	C1AE-6108-R	Piston—Std.—Red—390	16.34	BX	61-63	C1AE-6333-B	Main Bearing—Front, Front Intermed., Rear Intermed., Rear—Std. Blue—Upper & Lower—390, 406	2.05	A
61-62	C1AZ-6108-S	Piston—Std.—.060"—390	16.35	C	61-63	C1AE-6337-B	Main Bearing—Center—Std. Blue—Upper & Lower—390, 406	4.27	A
62-63	C2AZ-6108-B	Piston—Std.—Red—406	16.35	A	60-63	C1AE-6336-B	Crankshaft Rear Main Bearing Seal—352, 390, 406	.19	A
60	C0AE-6135-A	Piston Pin—Std.—352	.95	C	63	C3AZ-6366-A	Flywheel Housing Cover 4V & 6V	3.20	B
61-63	C1AE-6135-B	Piston Pin—Std.—use with C1AE-6140-A retainer—390, 406	.95	C					
60-63	C3AZ-6140-B	Piston Pin Retainer 352, 390, 406	.07	C					
62-63	C2AZ-6148-A	Piston Ring—Std.—406	8.61	A					
61-62	C1AZ-6148-A	Piston Ring—Std.—390	7.40	A					
60	B8AZ-6148-A	Piston Ring—Std.—352	7.65	A					
60	C1AE-6200-B	Connecting Rod Assy.—352	7.35	A					
61-63	C3AZ-6200-F	Connecting Rod Assy.—390, 406	7.35	A					



FORD 352, 390 AND 406 HIGH PERFORMANCE ENGINES GENERAL PARTS LIST (CONTINUED)

Year	Part Number	Description	Mfrs. Sugg. Retail Price	Class	Year	Part Number	Description	Mfrs. Sugg. Retail Price	Class
60-63	B8A-6366-A	Flywheel Housing Cover S/T & O/D—352, 390	7.80	A	61-63	C3AZ-6A630-A	Crankcase Ventilation Duct—390, 406	1.45	C
60-63	B8A-6375-A	Flywheel and Ring Gear Assy.—S/T & O/D—352, 390, 406	21.70	A	60-63	B9AZ-6A630-C	Crankcase Ventilation Duct—352, 390, 406	1.35	A
60-63	B8A-6384-A	Flywheel Ring Gear—352, 390, 406	4.55	BX	60-63	C0AE-6A631-A	Crankcase Vent. Oil Separator Element—352, 390, 406	.85	A
60-62	B9AA-6392-B	Flywheel Housing Assy.—352, 390, 406	20.36	A	60	C0AE-6A632-A	Crankcase Vent. Oil Separator Gasket—352	.17	C
63	C3AZ-6392-A	Flywheel Housing Assy.—406	20.36	B	61-63	C1AE-6A632-A	Crankcase Vent. Oil Separator Gasket—390, 406	.17	B
60-63	EAD-6397-A	Dowel-Cyl. Block to Flywheel Hsg.—352, 390, 406	.24	C	60-63	C0AE-6A633-A	Crankcase Vent. Oil Separator Element Retainer—352, 390, 406	.96	C
63	C3AZ-6411-B	Dust Seal—Engine Rear Cover Plate—390, 406	.15	C	60-63	C0AE-6A636-A	Oil Filter Adapter to Cyl. Block Gasket 390, 406 Crankcase Oil Cooler Spacer to Cyl. Block Gasket (61-63)	.17	B
63	C3AZ-6411-C	Dust Seal—Flywheel Housing Cover—390, 406	.15	C	60	C0AE-6A642-B	Crankcase Oil Cooler Assy.—352	342.50	CY
63	C3AZ-6435-B	Flywheel Housing Gasket—390, 406	.90	C	60-63	B8A-6659-A	Oil Pump to Block Gasket—352, 390, 406	.06	A
60-63	C4AZ-6500-B	Mechanical Tappet Assy.—352, 390, 406	1.40	A	61-63	C0ME-6670-A	Cyl. Block Main Oil Galley Relief Valve Plunger Spring—390, 406	.16	C
60-62	C2AZ-6505-A	Exhaust Valve—Std. 406 (62)—use w/C3AE-6090-C Cyl. Head—352, 390, 406	3.75	A	61-63	C1AE-6670-A	Oil Pump Body Relief Valve Spring—390, 406	.16	C
62-63	C3AZ-6505-E	Exhaust Valve Std.—use w/C3AE-6090-C Cyl. Hd.—406	7.54	A	61-63	B9AE-6674-B	Cyl. Block Main Oil Galley Relief Valve Plunger—390, 406	.51	B
60-63	C0AE-6507-N	Intake Valve—Std.—352, 390, 406	1.53	A	61-63	C1AE-6674-A	Oil Pump Body Relief Valve Plunger—390, 406	1.20	C
60-63	C3AZ-6513-A	Valve Spring—2 pc. design—352, 390, 406	1.50	A	60-63	C1AE-6675-F	Oil Pan Assy.—352, 390, 406	39.00	B
60-62	C2AZ-6514-A	Valve Spring Retainer—352, 390	.35	A	60-62	C0AE-6675-F	Oil Pan Assy.—extra capacity 352, 390	72.40	CY
62-63	C3AZ-6514-A	Valve Spring Retainer—406	.50	A	60	EAA-6700-B	Cyl. Front Cover Oil Head—352	1.20	A
60-63	B8A-6518-A	Valve Spring Retainer Ident. marking Red—352, 390, 406	.06	A	61-63	C3AZ-6700-A	Cyl. Front Cover Oil Seal—390, 406	1.20	A
60-63	C1SE-6524-A	Valve Spring Oil Baffle—352, 390, 406	2.40	B	60	B8QH-6701-B	Packing—Crankshaft—352	.18	AQ
63	C3AZ-6A536-A	Valve Spring Seat—use w/C3AZ-6049-A cyl. hd.—406	.25	C	61-63	C2OZ-6701-A	Packing Crankshaft—390, 406	.20	A
61-63	B6A-6549-C	Tappet and Rocker Arm Adjusting Screw—390, 406	.27	A	60-63	C0AE-6710-C	Oil Pan Gasket—352, 390, 406	.75	A
60-63	C3AZ-6563-A	Valve Rocker Arm Shaft—352, 390, 406	4.25	A	60-63	C1AZ-6731-A	Oil Filter Rotunda, 6000 Mile Type (R 1-A)	3.45	A
60-63	B8A-6564-B	Valve Rocker Arm and Screw Assy.—352, 390, 406	1.98	A	62-63	C2AZ-6758-E	Crankcase Ventilation Tube Assy.—with emission reduction control—390, 406	1.35	C
60-63	B8AZ-6565-C	Valve Push Rod—352, 390, 406	.92	AQ	60-63	C0AE-6758-E	Crankcase Ventilation Tube Assy.—non emission—Approx. 21-19/32" long—352, 390, 406	6.50	A
60-63	B8AZ-6571-B	Valve Guide and Valve Stem Seal—Intake & Exhaust—352, 390, 406	.11	A	60-63	C3AZ-6763-A	Oil Filler Pipe—352, 390, 406	.65	B
60-63	C3AZ-6582-D	Valve Rocker Arm Cover Assy.—Gold Metallic—R.H.—352, 390, 406	4.25	B	63	C3AZ-7007-B	Engine Rear Plate Assy.—S/T & O/D 406	3.15	C
60-63	C3AZ-6582-E	Valve Rocker Arm Cover Assy.—Gold Metallic—L.H.—352, 390, 406	4.25	B	63	C3AZ-7017-G	Transmission Input Shaft, 4/S/T 406	45.75	A
60-63	B9AE-6584-C	Valve Rocker Arm Cover Gasket—352, 390, 406	.75	A	60-63	8D-7065	Transmission Output Shaft Bearing—W/4/S	7.02	A
60-63	B8A-6587-B	Valve Rocker Arm to Shaft Locating Spring—352, 390, 406	.13	A	60-63	C2AZ-7029-A	Reverse Idler Gear Rear Thrust Washer W/4/S	.30	A
60-63	B8A-6590-A	Valve Rocker Arm Shaft Washer—352, 390, 406	.07	B	63	C3AZ-7102-E	Transmission Second Speed Gear—406 W/4/S	44.50	A
60	C0AE-6600-C	Oil Pump Assy.—352	15.15	BX	63	C3AZ-7113-H	Countershaft Cluster Gear—406 W/4/S—29-23-19-17 teeth	75.65	A
61-62	C3AZ-6600-A	Oil Pump Assy.—390, 406	16.55	A	63	C3AZ-7B340-B	Trans.—Third Speed Gear—W/4/S—29 helical teeth	36.00	A
60-63	C0AZ-6622-E	Oil Pump Screen, Tube & Cover Assy.—352, 390, 406	4.80	B	63	C3AZ-7515-B	Clutch Release Lever W/4/S—406	2.10	B
60-63	B8AZ-6626-A	Oil Pump Inlet Tube Fitting Gasket—352, 390, 406	.07	A	63	C3AZ-7521-D	Clutch Pedal Release Assy.—406 S/T		
60-63	B8A-6629-A	Oil Pump Intermediate Shaft Retainer Ring—352, 390, 406	.09	C	63	C3AZ-7523-B	Retracting Spring—Clutch Release W/4/S	.85	C
					63	C3AZ-7528-G	Clutch Release Equalizer Bar—406 S/T	5.55	B



FORD 352, 390 AND 406 HIGH PERFORMANCE ENGINES GENERAL PARTS LIST (CONTINUED)

Year	Part Number	Description	Mfrs. Sugg. Retail Price	Class	Year	Part Number	Description	Mfrs. Sugg. Retail Price	Class
63	C3AZ-7550-C	Clutch Disc—406 S/T & O/D	18.00	V	61-63	C1AE-9510-AV	Carburetor 6V—390, 406 (Inboard—1 reqd.)	30.55	CY
63	C2AZ-7563-A	Clutch Pressure Plate—406 S/T & O/D	14.60	V	61-63	C1AE-9510-AU	Carburetor 6V—390, 406 (Outboard—2 reqd.)	24.70	CY
60-62	C0AA-7550-B	Clutch Disc—4V & 6V—352, 390, 406 S/T & O/D	18.00	V	61-63	C3AZ-9510-G	Carburetor 4V—390, 406 (Tag Ident. C3AE-A)	56.25	C
60-65	B8A-7600-A	Clutch Pilot Bearing	1.50	A	63-64	C3AZ-9510-S	Carburetor 8V 406 (Tag Ident. C3AE-C)	79.45	C
FUEL SYSTEM					60-62	C0AE-9A589-A	Carburetor to Intake Manifold Spacer (except with emission reduction)	2.10	C
60-63	B7Q-9155-A	Fuel Filter Assy. (all)	5.35	A	62-63	C2AZ-9A589-E	Carburetor to Intake Manifold Spacer 390, 406 4V (with emission reduction)	5.40	C
60-63	C0AE-9180-A	Fuel Filter Bracket (all)			60	C1AZ-9502-B	Gasket Set For Carburetor #C0AE-9510-AA	2.70	A
61-63	C1AE-9D280-A	Carburetor Fuel Tube Assy.—6V 390, 406	14.00	CY	60	C0AZ-9590-L	Repair Kit—For Carburetor #C0AE-9510-AA	13.40	C
63-64	C3AZ-9D280-A	Carburetor Fuel Tube Assy.—8V	14.00	C	61-63	C1AZ-9502-C	Gasket Set for Carburetor #C1AE-9510-AV & C1AE-9510-AU (services complete (3) 2/B Carb. installation)	4.12	B
61-63	C3AZ-9D281-A	Carburetor Fuel Hose—(cut to fit)—6V, 8V—390, 406	.56	C	61-63	C1AZ-9590-H	Repair Kit—for Carburetor #C1AE-9510-AV & C1AE-9510-AU (services complete (3) 2/B Carb. installation)	22.00	B
60-63	C0AZ-9349-B	Fuel Pump Repair Kit (for C0AZ-9350-A)	5.25	C	61-63	C1AZ-9502-B	Gasket Set—for Carburetor #C1AE-9510-AM & #C3AZ-9510-G	2.70	A
60-63	C0AZ-9350-A	Fuel Pump Assy.	17.00	A	61-63	C1AZ-9590-G	Repair Kit—for Carburetor #C1AE-9510-AM & #C3AZ-9510-G	13.10	B
60-63	B7T-9364-A	Fuel Filter Bowl Gasket	.10	C	63-64	C1AZ-9502-B	Gasket Set—for Carburetor #C3AZ-9510—L, S	2.70	A
60-63	C4AZ-9365-A	Fuel Filter Element Assy.	.97	A	63-64	58MK-9590-K	Repair Kit—for Carburetor #C3AZ-9510—L, S	12.55	C
60-63	C3AZ-9424-C	Intake Manifold—4V	134.80	C	60-62	C0AE-9600-K	Air Cleaner Assy.—4V	42.25	C
61-63	C3AZ-9424-D	Intake Manifold—6V	134.80	C	61-63	C2SZ-9600-A	Air Cleaner Assy.—6V	59.10	A
62-63	C3AZ-9424-L	Intake Manifold—8V—406	147.15	C	63	C3AZ-9600-C	Air Cleaner Assy.—4V—406—(identified C3AF-9600-D)	22.65	C
60-63	C3AZ-9A424-A	Intake Manifold to Cyl. Block Seal—Rear	.25	A	63-64	C4AZ-9600-D	Air Cleaner Assy.—Chrome—4V 406 (except with closed emission system)—(identified C4AF-9600-D)	26.10	C
60-63	C3AZ-9A425-A	Intake Manifold to Cyl. Block Seal—Front	.25	A	60-64	C0AE-9601-C	Air Cleaner Element—4V (used with C0AE-9600-K, C3AZ-9600-C, C4AZ-9600-D)	6.90	A
60-63	C0AE-9A427-B	Exhaust Thermostat Control Valve Assy. (before 11-22-62)	13.25	A	61-63	EDJ-9601-A	Air Cleaner Element—6V (used with C2SZ-9600-A)	7.10	A
63	C3AZ-9A427-A	Exhaust Thermostat Control Valve Assy. (from 11-22-62)	13.25	B	60-62	C0AZ-9654-A	Air Cleaner to Carb. Gasket—4V—352, 390, 406	.25	A
63	C3AZ-9430-C	Exhaust Manifold—R.H.—406 (from 11-22-62)	34.50	C	61-63	C1AE-9654-A	Air Cleaner to Carb. Gasket—6V 390, 406	.50	C
60-63	C3AZ-9430-E	Exhaust Manifold—R.H.—352, 390, 406 (before 11-22-62)	36.10	B	63	C3AZ-9654-C	Air Cleaner to Carb. Gasket—4V—406—.188" thick	.25	C
63	C3AZ-9431-F	Exhaust Manifold—L.H.—406 (from 11-22-62)	34.50	C	63	C3AZ-9654-A	Air Cleaner to Carb. Gasket—4V—.06" thick	.25	C
60-63	C3AZ-9431-E	Exhaust Manifold—L.H.—4V, 6V 352, 390, 406 (before 11-22-62)	36.10	C	63	C3AZ-9732-C	Accelerator Bellcrank—406—8V	9.75	C
60-63	C3AZ-9433-A	Intake Manifold Gasket & Seal Set	2.00	A	63	C3AZ-9C760-A	Carb. Throttle Lever Trunnion—406 8V	1.35	C
60-63	C0AE-9A435-B	Exhaust Manifold to Muffler Inlet Pipe Spacer (Special Duty Performance only)	3.67	C	61-63	PB8M-9767-B	Carb. Throttle Synchrs. Rod End—390—6V, 406—6V-8V	1.65	C
60-63	C3AZ-9441-B	Intake Manifold to Cyl. Head Gasket—Heat Blocked (special duty performance only)	1.00	A					
61-63	C1AE-9447-C	Carburetor to Intake Manifold Gasket 6V 390, 406	.17	B					
60-63	C2AZ-9447-E	Carburetor to Intake Manifold Gasket 4V 390, 406	.21	A					
63	C3AZ-9A447-A	Exhaust Manifold Mounting Bolt Locking Tab—406 (from 11-22-62)	.13	C					
60-65	C0AA-9450-A	Exhaust Manifold to Exhaust Pipe Gasket	.42	A					
63	C3AZ-9A501-A	Carburetor Secondary Balance Tube—8V	.40	C					
60	C0AE-9510-AA	Carburetor 4V—352 (Tag Ident. CFAONA)	56.25	C					



FORD 352, 390 AND 406 HIGH PERFORMANCE ENGINES GENERAL PARTS LIST (CONTINUED)

Year	Part Number	Description	Mfrs. Sugg. Retail Price	Class	Year	Part Number	Description	Mfrs. Sugg. Retail Price	Class
60-63	C1AE-9819-B	Thermostatic Choke Control Outlet Tube—352, 390, 406-4V (before 11-22-62)	.50	C	63	C3SZ-10344-B	Alternator Pulley—4V or 6V—406 (Before 1-15-63)	3.00	C
61-63	C1AE-9819-C	Thermostatic Choke Control Outlet Tube—390, 406-6V (before 11-22-62)	2.15	CY	63	C3MY-10344-A	Alternator Pulley—4V or 6V—406 (From 1-15-63)	3.00	C
63	C3AZ-9819-B	Thermostatic Choke Control Outlet Tube 406—6V (from 11-22-62 & 8V (before 9-11-64)	2.30	C	63	C3SZ-10335-B	Alternator Rotor—406	14.20	B
63-64	C3AZ-9819-A	Thermostatic Choke Control Outlet Tube 406—4V (from 11-22-62)	.90	C	63	C3MY-10346-A	Alternator Assy.—406	59.80	C
61-63	C1AE-9B841-A	Carb. Throttle Rod—Front 6V—390, 406	2.95	CY	60-63	C1TZ-10002-A	Generator Regulator—4V, 6V or 8V	29.95	A
63	C3AZ-9B841-A	Carb. Throttle Rod—Front—8V—406	4.35	C	61-63	B8S-12043-B	Ignition Coil Mounting Strap	.52	C
61-63	C1AE-9B842-A	Carb. Throttle Rod—Rear—6V—390, 406	2.95	CY	61-63	C0AF-12127-K	Distributor Assy.—‡C0AF-12127-K (352, 390, 406)	65.00	A
63	C3AZ-9B842-B	Carb. Throttle Rod—Rear—8V—406	4.35	C	61-63	C0AF-12127-K	Distributor Assy.—‡C5AF-12127-AV (352, 390, 406)	65.00	A
COOLING AND GRILLE					63	C3AZ-12127-AE	Distributor Assy.—‡C3AF-12127-AE (406—8V)—Replaced by C5AZ-12127-E (use with Transistorized Ignition)	41.50	C
60-63	C3AZ-8005-B	Radiator Assy.	61.88	A	63	C5AZ-12127-E	Distributor Assy.—‡C5AF-12127-E (406—8V) (use with Transistorized Ignition)	41.50	C
62-63	C1AZ-8A080-B	Radiator Tank Assy.	15.85	A	60-63	C0AF-12152-A	Distributor Breaker Plate Assy. (352, 390, 406)	2.45	B
61-63	C2AZ-8501-B	Water Pump Assy.	24.00	B	60	FAB-12171-B	Distributor Breaker & Contact Point Set Assy. (352) Heavy-Duty	2.10	A
60	B8A-8509-A	Water Pump Pulley 352—4V	3.85	C	60	FDS-12171-A	Distributor Breaker & Contact Point Set Assy. (352) Regular	2.95	A
61-63	B7A-8509-B	Water Pump Pulley 390, 406	2.45	A	61-63	FDS-12171-A	Distributor Breaker & Contact Point Set Assy. (390, 406)—Use with C0AF-12127-K, C0AZ-12127-K, C3AZ-12127-AE, C5AZ-12127-E	2.95	A
60-63	C3AZ-8512-B	Water Pump Impeller		D	60-63	C2TZ-12188-A	Distributor Weight Assy. (352, 390, 406)—Use with C0AF-12127-H, C0AF-12127-J, C0AF-12127-K, C3AZ-12127-AE	1.40	A
61-63	B5S-8546-A	Pulley to Fan Spacer, 390, 406—1.28"	2.45	B	60-63	C5AZ-12188-A	Distributor Weight Assy. (352, 390, 406)—Use with C0AZ-12127-K	.87	A
62-63	C2AZ-8546-A	Pulley to Fan Spacer, 390, 406—1.19"	7.10	C	60-63	B7A-12191-B	Distributor Weight Spring—Secondary (352, 390, 406)—Use with C0AF-12127-H, C0AF-12127-J, C0AF-12127-K, C3AZ-12127-AE	.44	B
62-63	B9AE-8553-A	Water Pump Pulley Hub	1.65	B	63	C5AZ-12192-A	Distributor Weight Spring—Secondary (352, 390, 406)—Use with C0AZ-12127-K, C5AZ-12127-AE	.25	B
60-63	C0AE-8555-A	Water By-Pass Tube—352, 390, 406	.36	A	60	B8A-12192-A	Distributor Weight Spring—Primary (352)—Use with C0AF-12127-H, C0AF-12127-J	.15	C
60-63	C2RZ-8575-A	Water Thermostat—352, 390, 406—160°	3.25	A	60	B8QH-12192-C	Distributor Weight Spring—Primary (352, 390)—Use with C0AF-12127-K	.18	B
63-64	C3AZ-8575-B	Water Thermostat—390, 406—188°	3.25	A	63	B8QH-12192-C	Distributor Weight Spring—Primary (406)—Use with C3AZ-12127-AE	.18	B
61-63	C1AA-8600-E	4 Blade Fan Assy.—390, 406	3.95	CY	60-63	C5AZ-12192-D	Distributor Weight Spring—Primary (352, 390, 406)—Use with C0AZ-12127-K	.35	C
61	C1AA-8600-B	5 Blade Fan Assy.—390	6.70	A	63	C5AZ-12192-D	Distributor Weight Spring—Primary (406)—Use with C5AZ-12127-E	.35	C
62-63	C2AZ-8600-A	5 Blade Fan Assy.—406	10.65	A	60	C0AF-12210-B	Distributor Cam Assy. (352)—Use with C0AF-12127-J	3.40	B
62-63	C1MZ-8600-D	6 Blade Fan Assy.—390, 406	10.65	A	63				
63	C3AZ-8A611-C	Fan Guard—406—22.50" long—Chrome	8.90	C					
62-63	C2AZ-8A616-A	Fan Clutch Assy.—406	22.30	BX					
61-63	C2AZ-8620-B	Fan Belt—390, 406	3.25	B					
GENERATOR, STARTER, DISTRIBUTOR									
60-64	C3TZ-10505-B	Generator Voltage Regulator—352, 390—4V, 6V & 8V	8.65	A					
64	C1TF-10505-D	Generator Voltage Regulator—352, 390—4V	15.25	A					
60-61	C1TZ-10005-A	Generator Armature Assy.	22.00	A					
60-63	FAP-10130-A	Generator Pulley	4.15	A					
63	C3AZ-10170-D	Generator Splash Shield	2.30	C					
63-65	C3SZ-10316-B	Alternator Voltage Regulator	13.45	A					
63	C3SZ-10317-B	Alternator Splash Shield	.35	C					

‡Identification Number stamped on Distributor Housing.



FORD 352, 390 AND 406 HIGH PERFORMANCE ENGINES GENERAL PARTS LIST (CONTINUED)

Year	Part Number	Description	Mfrs. Sugg. Retail Price	Class
60-63	C3AZ-12210-A	Distributor Cam Assy. (352, 390, 406)—Use with C0AF-12127-H, C0AF-12127-K	6.00	C
60-63	C5AZ-12210-A	Distributor Cam Assy. (352, 390, 406)—Use with C0AZ-12127-K	6.00	C
63	C3AZ-12210-C	Distributor Cam Assy. (406)—Use with C3AZ-12127-AE	6.00	C
63	C5AZ-12210-B	Distributor Cam Assy. (406)—Use with C5AZ-12127-E	6.00	C
60	C0AF-12216-B	Distributor Primary Terminal Wire Assy.	.45	C
60-63	C3AZ-12259-F	Spark Plug Steel Core Wire Set	9.00	A
61-63	C3AZ-12298-A	High Tension Wiring Assy. (390, 406)	.83	C
60-63	7RA-12300-C	Distributor Condenser Assy. (352, 390, 406)—Use with C0AF-12127-H, C0AF-12127-J, C0AF-12127-K, C0AZ-12127-K, C3AZ-12127-AE	.93	A

Year	Part Number	Description	Mfrs. Sugg. Retail Price	Class
63	B9AF-12300-A	Distributor Condenser Assy. (406)—Use with C5AZ-12127-E	.93	A
SPEEDOMETER				
62-63	C2AZ-17285-A	Speedometer Driving Gear—4/S/T—7 teeth—Steel	3.70	B
SHOCK ABSORBERS				
61-62	C1AZ-18124-K	Front Shock Absorber Kit—H/D	9.80	A
61	C1AZ-18125-H	Rear Shock Absorber Kit—H/D	8.10	A
63-64	C4MY-18124-A	Front Shock Absorber Kit—H/D	9.80	A
63-64	C4AZ-18125-E	Rear Shock Absorber Kit—H/D	9.80	A

†Identification Number stamped on Distributor Housing.



FORD 289 HIGH PERFORMANCE ENGINE GENERAL PARTS LIST

Year	Part Number	Description	Mfrs. Sugg. Retail Price	Class
WHEELS AND BRAKES				
65	C5ZZ-2282-D	Rear Brake Hose Assy.—Mustang 4/S/T	2.65	C
63-65	C3OZ-2631-B	Parking Brake Equalizer Bracket—Fairlane	1.55	C
62-65	C2OZ-2007-C	Brake Shoe Lining Kit—Front—Fade Resistant—Fairlane	7.45	B
62-65	C2OZ-2007-D	Brake Shoe Lining Kit—Rear—Fade Resistant—Fairlane	6.50	B
FRONT SUSPENSION—STEERING—REAR AXLE				
65	C2OZ-3468-B	Front Suspension Lower Arm—Fairlane	3.20	C
63-64	C3OZ-4010-B	Rear Axle Housing Assy.—Axle Model WCU—(Before 12-1-63)	59.35	C
64-65	C3OZ-4010-C	Rear Axle Housing Assy.—Axle Model WCU—(From 12-1-63)	59.35	C
65	C5ZZ-4010-A	Rear Axle Housing Assy.—Axle Models WCZ-H, -J—Mustang	58.80	C
65	C5ZZ-4022-A	Rear Brake Line Connection Vent Assy.—Axle Models WCZ-H, -J—Mustang	.56	C
65	B7A-4035-A	Rear Axle Carrier Gasket—Axle Models WCZ-H, -J—Mustang	.22	A
65	C0AZ-4141-A	Differential Carrier Assy.—Axle Models WCZ-H, -J—Mustang	34.30	A
65	C2AZ-4204-B	Differential Gear Case Assy.—Axle Models WCZ-H, -J—Mustang	16.80	A
63-65	C2AZ-4204-B	Differential Gear Case Assy.—Axle Model WCU—Fairlane	16.80	A
65	B7AZ-4209-E	Differential Gear and Pinion Kit—3.89 to 1 ratio—Mustang—Axle Model WCZ-H	45.65	A
62-65	B7AZ-4209-E	Differential Gear Case Assy.—Axle Model WCU—Fairlane	45.65	A
63-65	B7AZ-4209-C	Differential Gear and Pinion Kit—4.11 to 1 ratio—Fairlane (Axle Model WCU-D) and Mustang (Axle Model WCZ-H)	45.65	A
63-65	C3AZ-4209-D	Differential Gear and Pinion Kit—4.11 to 1—Fairlane	50.00	C
64-65	C4AZ-4209-A	Differential Gear & Pinion Kit—3.10 to 1—9" Ring Gear	125.00	CY

Year	Part Number	Description	Mfrs. Sugg. Retail Price	Class
64-65	C4AZ-4209-B	Differential Gear & Pinion Kit—3.40 to 1—9" Ring Gear	125.00	CY
64-65	C4AZ-4209-C	Differential Gear & Pinion Kit—4.33 to 1—9" Ring Gear	125.00	CY
64-65	C4AZ-4209-E	Differential Gear & Pinion Kit—4.71 to 1—9" Ring Gear	125.00	CY
63-65	C4AZ-4209-F	Differential Gear & Pinion Kit—4.86 to 1—9" Ring Gear	125.00	C
63-65	C4AZ-4209-G	Differential Gear & Pinion Kit—5.14 to 1—9" Ring Gear	125.00	CY
64-65	C4AZ-4209-H	Differential Gear & Pinion Kit—5.43 to 1—9" Ring Gear	125.00	CY
63-65	C4AZ-4209-J	Differential Gear & Pinion Kit—5.67 to 1—9" Ring Gear	125.00	CY
65	C1AZ-4215-B	Differential Shaft Pinion Kit—Axle Models WCZ-H, -J—Mustang	5.93	A
64	C4OZ-4602-H	Drive Shaft—4/S/T (Rubber Insulated)	40.70	C
64-65	C4OZ-4602-F	Drive Shaft—4/S/T—Fairlane	40.70	C
64-65	C4OZ-4602-G	Drive Shaft—C4—Fairlane	40.70	C
65	C5ZZ-4602-E	Drive Shaft—4/S/T—Mustang	40.70	C
63-65	C2AZ-4614-A	Driving Pinion Bearing Retainer and Bearing Cup Assy.—Fairlane and Mustang	12.25	A
63-65	B7A-4616-A	Driving Pinion Bearing Cup—Fairlane and Mustang	1.74	A
63-65	B7A-4621-A	Driving Pinion Bearing Cone and Roller—Fairlane and Mustang	3.62	A
65	C2AZ-4676-A	Driving Pinion Oil Seal Assy.—Mustang	2.00	A
65	C3AZ-4730-B	Bumper—Rear Axle Carrier—Mustang	1.40	C
65	C3OZ-4730-D	Rear Axle Bumper—Carrier—Fairlane	1.55	C

FRONT SPRING AND STABILIZER

64	C3OZ-5310-H	Front Spring—1765#—3/S/T—Fairlane	9.00	B
64-65	C3OZ-5310-K	Front Spring—1815#—4/S/T, C4—Fairlane	9.00	B
65	C5ZZ-5310-E	Front Spring—1516#—4/S/T—Mustang (Before 8-20-64)	9.00	C



FORD 289 HIGH PERFORMANCE ENGINE GENERAL PARTS LIST (CONTINUED)

Year	Part Number	Description	Mfrs. Sugg. Retail Price	Class	Year	Part Number	Description	Mfrs. Sugg. Retail Price	Class
65	C5ZZ-5310-E	Front Spring—1491#—3/S/T—Mustang (From 8-20-64)	9.00	C	64-65	C40Z-6010-C	Cylinder Block Assy.—uses front cover without oil fill hole—#5 bolt holes for flywheel housing, 1964 Fairlane 1965 Mustang	144.90	B
65	C5ZZ-5310-F	Front Spring—1438#—4/S/T—Mustang (Before 8-20-64)	9.00	C	65	C50Z-6010-A	Cylinder Block Assy.—(6) holes for flywheel housing—Fairlane & Mustang	107.00	B
65	C5ZZ-5310-F	Front Spring—1413#—3/S/T—Mustang (From 8-20-64)	9.00	C	63-64	C20Z-6028-B	Engine Front Support Bracket Assy.—R.H. & L.H.—Fairlane—(before 3/3/64)	3.50	A
65	C30Z-5482-D	Stabilizer Assy.—Fairlane	10.65	C	64	C3DZ-6028-C	Fairlane—R.H.—(from 3/3/64)	3.50	B
65	C5ZZ-5482-A	Stabilizer Assy.—Mustang	10.65	C	65	C50Z-6028-A	Engine Front Support Bracket Assy.—R.H. & L.H.—Fairlane	3.50	C
65	C5ZZ-5493-A	Stabilizer to Suspension Lower Arm Insulator—Mustang	.49	C	65	C5ZZ-6028-A	Engine Front Support Bracket Assy.—R.H.—Mustang 4/S/T	3.50	C
65	C50Z-5484-B	Stabilizer to Suspension Lower Arm Insulator—Fairlane	.76	C	64	C3DZ-6029-C	Fairlane—L.H.—(from 3/3/64)	3.50	B
REAR SPRING									
64	C40Z-5560-D	Rear Leaf Spring Assy.—H/D 4-Leaf—stamped C40A-5560-E, F—Fairlane	20.25	B	65	C5ZZ-6029-A	Engine Front Support Bracket Assy.—L.H.—Mustang	3.50	C
65	C50Z-5560-D	Rear Leaf Spring Assy.—H/D 4-Leaf—stamped C40A-5556-E-F—Fairlane	20.25	B	63-64	C20Z-6030-B	Fairlane—R.H. & L.H.	1.70	B
64	C40Z-5564-A	Rear Spring Leaf No. 1 (for C40Z-5560-D)—Fairlane	11.05	B	65	C50Z-6030-A	Engine Front Mounting Bracket Assy.—R.H. & L.H.—Fairlane	1.70	C
64	C40Z-5565-A	Rear Spring Leaf No. 2 (for C40Z-5560-D)—Fairlane	7.45	C	65	C5ZZ-6030-A	Engine Front Mounting Bracket Assy.—R.H.—Mustang	3.50	C
65	C5ZZ-5560-E	Rear Leaf Spring Assy.—4 Leaf—stamped C4ZA-5556-K-L-S-Y (3/S/T, 4/S/T)—Mustang	19.95	C	63-64	C20Z-6038-A	Fairlane—R.H. & L.H.	3.00	A
65	C5ZZ-5560-F	Rear Leaf Spring Assy.—4 Leaf—stamped C4ZA-5556-H-J-R-V (3/S/T, 4/S/T)—Mustang	19.95	C	65	C5ZZ-6031-A	Engine Front Mounting Bracket Assy.—L.H.	3.50	C
65	C5ZZ-5564-B	Rear Spring Leaf #1 (for C5ZZ-5560-E, F)—Mustang	11.05	C	65	C5ZZ-6038-A	Engine Front Support Insulator Assy.—Fairlane & Mustang	3.00	C
65	C5ZZ-5565-B	Rear Spring Leaf #2 (for C5ZZ-5560-E, F)—Mustang	5.80	C	63-64	C30Z-6049-H	Cylinder Head—Ident. #C30E-6051-C (before 4/2/64)—Fairlane	53.55	C
65	C4DZ-5630-C	Rear Spring Shackle Kit—Front—Mustang	2.10	B	64-65	C50Z-6049-A	Cylinder Head (from 4/2/64)	59.15	C
65	C5DZ-5796-A	Rear Spring Clip Plate—R.H.—Mustang	2.20	C	63-65	C3AZ-6051-C	Cylinder Head Gasket— asbestos and steel	2.75	A
65	C5DZ-5796-B	Rear Spring Clip Plate—L.H.—Mustang	2.20	C	63-65	C1SS-6054-A	Engine Rear Support Retainer—Fairlane	.60	C
ENGINE ASSEMBLY									
<p>Includes: Carburetor, manifolds, oil filter, oil pan, oil pump, water pump, distributor, spark plugs, ignition wiring and ignition coil, flywheel or clutch housing, clutch and flywheel (except for automatic transmission type), water connections and all covers.</p> <p>Does not include: Starter, generator, fuel pump, air cleaner, fan or fan belts and breather tubes (unless indicated).</p>									
65	C50E-6007-D563J	Engine Assembly—4V—S/T & O/D—Fairlane	810.65	L	65	C5ZZ-6068-C	Engine Rear Support Assy.—Mustang 4/S/T	1.60	C
65	C5ZE-6007-D554J	Engine Assembly—4V—S/T—Mustang	810.65	L	65	C30Z-6068-B	Engine Rear Support Assy.—Fairlane	1.85	A
65	C50E-6007-D564J	Engine Assembly—4V—C4—Fairlane	770.65	L	63-64	C20Z-6068-C	Engine Rear Support Assy.—Fairlane (exc. 4/S/T)	1.85	A
ENGINE COMPONENTS									
63	C30Z-6009-D	Cylinder Assy.—Mechanical Tappets (less tappets)—Fairlane	353.85	C	63-64	C1AA-6068-A	Engine Rear Support Assy.—Fairlane (4/S/T)	1.85	A
64-65	C40Z-6009-E	Cylinder Assy.—Mechanical Tappets (less tappets) #5 bolt holes for flywheel housing.	353.85	C	65	C5ZZ-6068-A	Engine Rear Support Assy.—Mustang (exc. 4/S/T)	2.60	A
65	C50Z-6009-B	Cylinder Assy.—Mechanical Tappets (less tappets) #6 bolt holes for flywheel housing	353.85	C	63-64	C30Z-6108-K	Piston—Std.—Red (before 4/2/64)—Fairlane	6.05	C
63	C30Z-6010-D	Cylinder Block Assy.—uses front cover with oil fill hole—Fairlane	144.90	C	64-65	C30Z-6108-L	Piston—Std.—Red (from 4/2/64) Fairlane, Mustang	6.05	C
63-65	C1AE-6214-A	Connecting Rod Bolt—Fairlane	.36	A	63-65	B2AZ-6135-A	Piston Pin—Std.—Green Ident. Marking.	.95	B
63-65	C30Z-6200-C	Connecting Rod Assy.	9.85	C	63-65	C3AZ-6148-B	Piston Ring Std.	7.65	A
63-65	C30Z-6211-A	Connecting Rod Bearing—Std. Red	.89	B	63-65	C30Z-6200-C	Connecting Rod Assy.	9.85	C
63-65	C30Z-6211-B	Connecting Rod Bearing—Std. Blue	.89	B	63-65	C30Z-6211-A	Connecting Rod Bearing—Std. Red	.89	B
63-65	C1TE-6212-A	Connecting Rod Nut—Fairlane, Mustang	.16	A	64-65	C40Z-6214-B	Connecting Rod Bolt	.36	C
64-65	C40Z-6214-B	Connecting Rod Bolt	.36	C	63	C1AE-6214-A	Connecting Rod Bolt—Fairlane	.36	A
63	C1AE-6214-A	Connecting Rod Bolt—Fairlane	.36	A	63-65	C30Z-6250-C	Camshaft Assy.—Less Gear	29.45	B
63-65	C30Z-6250-C	Camshaft Assy.—Less Gear	29.45	B	63-65	C30Z-6256-A	Camshaft Sprocket—Cast Iron (before 1/4/65)—Fairlane, Mustang	4.70	C



FORD 289 HIGH PERFORMANCE ENGINE GENERAL PARTS LIST (CONTINUED)

Year	Part Number	Description	Mfrs. Sugg. Retail Price	Class	Year	Part Number	Description	Mfrs. Sugg. Retail Price	Class
65	C50Z-6256-A	Camshaft Sprocket—Nylon & Alum. (from 1/4/65)	4.70	B	65	C5DZ-6392-A	Flywheel Housing Assy.—Mustang 4/S/T (from 8/20/64)—6 engine mounting holes	20.36	B
63-65	C20Z-6261-A	Camshaft Bearing—Front—Std.—Fairlane, Mustang	1.36	B	63-65	C30Z-6500-A	Mechanical Tappet Assy. Fairlane, Mustang	2.75	A
63-65	C20Z-6267-A	Camshaft Bearing—Front Intermed.—Std. Fairlane, Mustang	1.36	B	63-65	C30Z-6505-A	Exhaust Valve Std.—Fairlane, Mustang	7.54	B
63-65	C20Z-6262-A	Camshaft Bearing—Center—Std.—Fairlane, Mustang	1.36	B	63-64	C30Z-6507-A	Intake Valve Std.—Chrome (Fairlane from 4/2/64)	2.27	B
63-65	C20Z-6270-A	Camshaft Bearing—Rear Intermed.—Std. Fairlane, Mustang	1.36	B	64-65	C40Z-6507-A	Intake Valve—Chrome—Std. (Fairlane from 4/2/64 & Mustang)	2.64	B
63-65	C20Z-6263-A	Camshaft Bearing—Rear—Std.—Fairlane, Mustang	1.36	B	63-65	C30Z-6513-A	Valve Spring—2 pc. design—Fairlane, Mustang	1.50	B
63-65	C30Z-6265-A	Camshaft Sprocket Spacer	.25	C	63-65	C30Z-6514-A	Valve Spring Retainer—Fairlane, Mustang	.50	B
63-65	C30Z-6268-A	Timing Chain—58 links	8.50	B	63-65	7HA-6518-A	Valve Spring Retainer—Fairlane, Mustang	.08	A
63-65	C30Z-6269-A	Camshaft Thrust Plate— $\frac{3}{8}$ " thick (before 1/4/65)—Fairlane, Mustang	.96	C	63-65	C20Z-6524-A	Baffle—Valve Push Rod Valley—Fairlane, Mustang	.42	C
65	C50Z-6269-A	Camshaft Thrust Plate— $\frac{1}{4}$ " thick (from 1/4/65)—Fairlane, Mustang	.96	B	63-65	C30Z-6A527-A	Valve Rocker Arm Support Stud, Fairlane, Mustang	.80	C
63-65	C20Z-6278-A	Camshaft Sprocket Washer—Fairlane, Mustang	.16	C	63-65	C20Z-6A528-A	Valve Rocker Arm Fulcrum Seat—Fairlane, Mustang	.16	A
63-65	C3AZ-6287-B	Camshaft Fuel Pump Drive Eccentric—Fairlane, Mustang	2.20	B	63-65	C20Z-6564-A	Valve Rocker Arm—Fairlane, Mustang	.67	A
63-65	C30Z-6303-B	Crankshaft—Fairlane, Mustang	105.65	C	63-65	C20Z-6565-B	Valve Push Rod—Fairlane, Mustang	.47	A
63-65	C30Z-6306-A	Crankshaft Sprocket—21 teeth—steel—Fairlane, Mustang	5.15	C	63-65	C30Z-6571-B	Valve Guide & Valve Stem Seal Rubber—Intake & Exhaust—Fairlane, Mustang	.08	C
63-65	C30Z-6310-A	Crankshaft Oil Slinger—Fairlane, Mustang	.55	C	63	C3DZ-6582-C	Valve Rocker Arm Cover Assy.—Chrome—Fairlane—R.H. & L.H.	9.65	B
63-65	C30Z-6316-A	Crankshaft Damper—63-64 Fairlane & 65 Mustang (before 8/20/64)	12.60	C	64-65	C4AZ-6582-A	Valve Rocker Arm Cover Assy.—Red—Fairlane (before 10/30/64) R.H.	5.40	B
65	C50Z-6316-A	Crankshaft Damper Fairlane, (Mustang from 8/20/64)	12.60	C	64-65	C4AZ-6582-B	Valve Rocker Arm Cover Assy.—Red—Fairlane (before 10/30/64) L.H.	5.40	B
63-65	C3AZ-6333-B	Main Bearing—Front, Front Intermed., Rear Intermed., Rear—Std. Blue—Upper—Fairlane, Mustang	1.19	A	65	C4AZ-6582-C	Valve Rocker Arm Cover Assy.—Primed—Fairlane & Mustang (from 10/30/64) R.H.	5.40	B
63-65	C3AZ-6337-B	Main Bearing—Center—Std.—Upper Fairlane, Mustang	3.03	A	65	C4AZ-6582-B	Valve Rocker Arm Cover Assy.—Red Fairlane & Mustang (from 10/30/64) L.H.	5.40	B
63-65	C3AZ-6333-J	Main Bearing—Front, Front Intermed., Rear Intermed., Rear—Std.—Lower—Fairlane, Mustang	1.19	A	65	C4DZ-6582-C	Valve Rocker Arm Cover Assy.—Chrome—Fairlane & Mustang—R.H.	9.65	C
63-65	C3AZ-6337-J	Main Bearing—Center—Std.—Lower—Fairlane, Mustang	3.03	A	65	C4DZ-6582-B	Valve Rocker Arm Cover Assy.—Chrome—Fairlane & Mustang—L.H.	9.65	C
63-65	C20Z-6345-A	Crankshaft Main Bearing Cap Bolt—Fairlane, Mustang	.31	C	65	C4DZ-6582-A	Valve Rocker Arm Cover Assy.—Chrome—Mustang R.H. (before 10/30/64)	9.65	C
63-65	C30Z-6A360-A	Crankshaft Counterweight—Fairlane, Mustang	2.30	C	65	C4DZ-6582-B	Valve Rocker Arm Cover Assy.—Chrome—Mustang L.H. (before 10/30/64)	9.65	C
63-65	C30Z-6375-C	Flywheel and Ring Gear Assy.—Fairlane (63-64) 4/S/T & Mustang (65) 3/4/S/T	30.95	C	63-65	C20Z-6584-A	Valve Rocker Arm Cover Gasket—Fairlane, Mustang	.75	A
64-65	C40Z-6375-C	Flywheel Assy. Fairlane C4	30.95	C	63-65	C20Z-6600-A	Oil Pump Assy.—Fairlane, Mustang	15.15	A
65	C50Z-6375-A	Flywheel Assy. 4V Fairlane 4/S/T	30.95	C	63-65	C30Z-6622-A	Oil Pump Screen, Tube & Cover Assy.—Fairlane, Mustang	2.30	B
63-65	C30Z-6378-A	Crankshaft Pulley or Damper Retaining Washer—Fairlane, Mustang	.56	C	63-65	C20Z-6626-A	Oil Pump Screen Cover & Inlet Tuber Gasket—Fairlane, Mustang	.07	B
63-65	C20Z-6384-A	Flywheel Ring Gear—Fairlane (63-64) 4/S/T & Mustang (65)—3/4/S/T	4.40	A	63-65	B8A-6629-A	Oil Pump Intermediate Shaft Retainer—Fairlane, Mustang	.09	C
65	C5AZ-6384-B	Flywheel Ring Gear—Fairlane 4/S/T	4.40	B	63-65	C20Z-6A630-A	Crankcase Ventilation Duct—Fairlane	.42	C
65	C5AZ-6392-A	Flywheel Housing Assy. Fairlane 4/S/T—6 engine mounting holes	20.36	B	63-64	C20Z-6A631-A	Crankcase Vent. Oil Separator Element—Fairlane	.75	A
63-65	C30Z-6392-C	Flywheel Housing Assy.—Fairlane (63-64) 3/4/S/T & (Mustang 3/4/S/T 65—Before 8/20/64)—5 engine mounting holes	20.36	B	65	C50Z-6A631-A	Crankcase Vent. Oil Separator Element—Fairlane, Mustang	.75	C



FORD 289 HIGH PERFORMANCE ENGINE GENERAL PARTS LIST (CONTINUED)

Year	Part Number	Description	Mfrs. Sugg. Retail Price	Class	Year	Part Number	Description	Mfrs. Sugg. Retail Price	Class					
63-65	C20Z-6659-A	Oil Pump to Block Gasket—Fairlane, Mustang	.07	B	63-65	C20Z-6670-A	Oil Pump Body Relief Valve Spring—Fairlane, Mustang	.29	C					
63-65	C20Z-6674-A	Oil Pump Body Relief Valve Plunger—Fairlane, Mustang	.40	C	63-65	C40Z-6675-A	Oil Pan Assy.—“COBRA”—finned aluminum—extra capacity—Fairlane, Mustang	80.80	VA					
63-65	C5AZ-6675-B	Oil Pan Assy. (Must be used with C30Z-6622-A cover)—Fairlane, Mustang	13.45	A	63-65	C3AZ-6700-A	Cyl. Front Cover Oil Seal—Fairlane, Mustang	1.20	A					
63-65	C1AZ-6731-A	Oil Filter Rotunda, 6000 Mile Type (R1-A)	3.45	A	63-65	C1TZ-6731-D	Oil Filter Element Rotunda, 6000 Mile Type (R1-C) Fairlane	2.00	A					
63-65	C20Z-6781-A	Oil Pan Gasket Set—Fairlane, Mustang	1.75	A	63-65	C5AZ-6840-A	Oil Filter Adapter Gasket—3/S/T Fairlane	.30	B					
63-65	C20Z-6881-B	Oil Filter Adapter & Insert Assy.	3.05	C	63-65	C20Z-6881-B	Oil Filter Adapter & Insert Assy.	3.05	C					
TRANSMISSION—CLUTCH														
63-64	C30Z-7003-H	Transmission and Extension Assy.—4 Speed—Fairlane	387.30	C	63-65	C30Z-7550-F	Clutch Disc—Fairlane & Mustang—S/T, O/D, F & W/4/S	16.70	V					
65	C30Z-7003-K	Transmission and Extension Assy.—4 Speed—Ident. “HEK-K”—Fairlane	387.50	C	64-65	C30Z-7563-A	Clutch Pressure Plate—Fairlane & Mustang S/T, O/D, F & W/4/S	34.75	V					
64	C40Z-7003-B	Transmission and Extension Assy.—4 Speed—Ident. “HEH-E”—Fairlane Special Duty Performance	198.75	C	FUEL SYSTEM									
65	C5ZZ-7003-E	Transmission and Extension Assy.—4 Speed—Ident. “HEH-S”—Mustang (before 8-20-64)—5 engine mounting holes	387.30	C	65	C50Z-9350-A	Fuel Pump & Filter Assy.—Fairlane & Mustang	12.80	B					
65	C5ZZ-7003-H	Transmission and Extension Assy.—4 Speed—Ident. “HEH-T” Mustang (from 8-20-64) 6 eng. mounting holes	387.30	C	65	C2AZ-9364-A	Fuel Pump Filter Bowl Gasket	.10	A					
65	C40Z-7017-A	Transmission Input Shaft—Fairlane, Mustang 4/S/T	19.26	B	65	C5AZ-9365-A	Fuel Pump Filter Element Assy.	1.23	A					
63-65	C30Z-7017-F	Transmission Input Shaft—Mustang, Fairlane W/4/S	32.95	B	63	C30Z-9424-C	Intake Manifold—Fairlane	34.50	B					
63-65	8D-7025	Transmission Input Shaft Bearing—4/S/T	10.05	A	64-65	C40Z-9424-B	Intake Manifold—1964 Fairlane & 1965 Mustang (before 8-20-64)	34.50	C					
63-65	8D-7065	Transmission Output Shaft Bearing—4/S/T	7.02	A	65	C40Z-9424-C	Intake Manifold—Fairlane & Mustang (from 8-20-64 to 9-8-64)	34.50	C					
63-65	C3AZ-7029-A	Reverse Idler Gear Rear Thrust Washer S/T	.30	A	65	C40Z-9424-D	Intake Manifold—Fairlane & Mustang (from 9-8-64)	34.50	C					
65	C5AZ-7050-D	Input Shaft Bearing Retainer—W/4/S	5.95	C	63-64	C30Z-9430-B	Exhaust Manifold—R.H.—Fairlane (before 4-1-64)	16.30	C					
65	C4AZ-7050-A	Input Shaft Bearing Retainer—F/4/S (Mustang)	5.95	B	64	C30Z-9430-C	Exhaust Manifold—R.H.—Fairlane (from 4-1-64)	16.30	C					
65	C5ZZ-7061-A	Output Shaft—F/4/S (Mustang)	43.40	C	65	C5ZZ-9430-A	Exhaust Manifold—R.H.—Fairlane & Mustang	16.30	C					
64-65	C4AZ-7102-D	Transmission Second Speed Gear—F/4/S	21.25	A	63-65	C30Z-9431-A	Exhaust Manifold—L.H.—Fairlane & Mustang	16.30	C					
65	C5ZZ-7B112-A	Reverse Gearshift Rod Mustang—F/4/S	2.75	B	63-65	C3AZ-9433-B	Intake Manifold Gasket & Seal Set	2.00	A					
65	C5ZZ-7B112-C	Reverse Gearshift Rod Mustang—W/4/S			63-65	C30Z-9A447-A	Exhaust Manifold Mounting Bolt Locking Tab	.25	C					
65	C3AZ-7113-L	Countershaft Cluster Gear—W/4/S 29-23-19-17 teeth (Fairlane)	50.30	A										
4-65	C4AZ-7113-A	Countershaft Cluster Gear—F/4/S 25-21-18-15 teeth (Fairlane & Mustang)	34.75	A										
65	B7AZ-7A283-A	Input Shaft Oil Seal—F/4/S Mustang	.95	A										
65	C3AZ-7B340-D	Trans. Third Speed Gear W/4/S—Fairlane	36.00	B										
65	C4AZ-7B340-B	Trans. Third Speed Gear—F/4/S—25 helical teeth—Mustang	36.00	A										
65	C5ZZ-7A039-E	Extension Housing Assy.—W/4/S—Mustang	49.00	C										
65	C5ZZ-7A039-D	Extension Housing Assy.—F/4/S—Mustang	25.50	C										
65	C5ZZ-7285-C	3rd & 4th Shift Fork Cam & Shaft Lever—F/4/S—Mustang	1.45	C										
65	C5ZZ-7290-F	1st & 2nd Shift Fork Cam & Shaft Lever—F/4/S—Mustang	.87	C										
65	C5ZZ-7290-G	Reverse Shift Fork Cam & Shaft Lever—F/4/S—Mustang	.87	C										
65	C5ZZ-7326-E	3rd & 4th Speed Connecting Gear Shift Rod—F/4/S—Mustang	3.15	C										
65	C5ZZ-7328-C	1st & 2nd Speed Connecting Gear Shift Rod—F/4/S—Mustang	2.70	C										
65	C50Z-7528-A	Clutch Release Equalizer Bar—Fairlane	5.55	C										
65	C5ZZ-7528-C	Clutch Release Equalizer Bar—Mustang, 6.30" long	5.55	B										
65	C5ZZ-7528-D	Clutch Release Equalizer Bar—Mustang, 6.30" long	5.55	B										
65	C50Z-7A531-A	Clutch Release Equalizer Shaft Ball Inner Pivot—F & W/4/S	.60	C										



FORD 289 HIGH PERFORMANCE ENGINE GENERAL PARTS LIST (CONTINUED)

Year	Part Number	Description	Mfrs. Sugg. Retail Price	Class
63-64	C30Z-9510-J	Carburetor (Tag. Ident. C30F-AJ)—Fairlane	54.65	B
64-65	C40Z-9510-D	Carburetor (Tag Ident. C40F-AL, AT, BU, BT, C4ZF-G, H, C50F-J, K)—Fairlane & Mustang	54.65	C
65	C40Z-9510-F	Carburetor (Tag Ident. C50F-L, M, T, U)—Fairlane & Mustang	54.65	C
63-65	C2SZ-9502-A	Gasket Set—For Carb. #C40Z-9510-D and C40Z-9510-F (before 10-26-64), C30Z-9510-G, J	.75	A
64-65	C2SZ-9502-B	Gasket Set—for Carb. #C40Z-9510-D and C40Z-9510-F (from 10-26-64)	.75	A
63-64	C2SZ-9A586-A	Tune-Up Kit—for Carb. #C30Z-9510-G, J	4.80	A
64-65	C40Z-9A586-A	Tune-Up Kit—for Carb. #C40Z-9510-D and C40Z-9510-F (before 10-26-64)	5.85	A
64-65	C40Z-9A586-B	Tune-Up Kit—for Carb. #C40Z-9510-D and C40Z-9510-F (from 10-26-64)	5.85	A
63-64	C2SZ-9590-A	Repair Kit—For Carb. #C30Z-9510-G, J	8.10	A
64-65	C40Z-9590-B	Repair Kit—for Carb. #C40Z-9510-D (tag codes C40F-AL, AT, BU, BT, C4ZF-G, H) and C40Z-9510-F	8.45	A
64-65	C50Z-9590-A	Repair Kit—for Carb. #C40Z-9510-D (tag codes C50F-J, K)	8.45	A
63-64	C4AZ-9600-E	Air Cleaner Assy.—Fairlane—Gold Metallic (except with closed emission system) (before 4-2-64)—Identified C4AF-9600-E, ED-C4AF-9600-E, C3AF-9600-L, C30F-9600-G, J	22.65	C
64	C40Z-9600-T	Air Cleaner Assy.—Fairlane—Gold Bronze—(with closed emission system)—Identified—C40F-9600-T, R	22.65	C
64	C40Z-9600-N	Air Cleaner Assy.—Fairlane (exc. with closed emission system) (from 4-2-64)—Identified C40F-9600-N, C4ZF-9600-Y	22.65	C
65	C40Z-9600-N	Air Cleaner Assy.—Mustang (exc. with closed emission system) (before 8-20-64)—Identified C40F-9600-N, C4ZF-9600-Y	22.65	C
65	C5ZZ-9600-V	Air Cleaner Assy.—Mustang (with closed emission system) (before 8-20-64)—Identified C4ZF-9600-V	22.65	C
65	C5ZZ-9600-W	Air Cleaner Assy.—Fairlane & Mustang (from 8-20-64)—Identified C50F-9600-C, D, C5AF-9600-M, S	26.10	C
63-65	B7S-9601-A	Air Cleaner Element—Fairlane & Mustang	4.80	A
64	C30Z-9700-A	Carb. Choke Control Assy.—Fairlane—cut to 38.62" long	1.60	A
65	C5ZZ-9700-B	Carb. Choke Control Assy.—Mustang—63.06" long (before 6-1-64)	1.60	C
65	C50Z-9700-A	Carb. Choke Control Assy.—Fairlane—58.00" long—7/16"—14 thread	1.60	A
65	C5ZZ-9700-C	Carb. Choke Control Assy.—Mustang—57.62" long—7/16"—14 thread—(from 6-1-64)	1.60	C
65	C50Z-9A700-A	Carb. Choke Control Mounting Bracket—Fairlane	.16	C
65	C5ZZ-9A700-A	Carb. Choke Control Mounting Bracket—Mustang	.16	C
64-65	C40Z-9772-A	Accelerator Belcrank to Carburetor Rod Assy.—Fairlane—with C4	1.00	C
64-65	C40Z-9784-A	Accelerator to Trans. Control Shaft Rod Assy.—Fairlane—4V with C4	1.35	C

Year	Part Number	Description	Mfrs. Sugg. Retail Price	Class
COOLING AND GRILLE				
63	C30Z-8005-C	Radiator Assy.—4V—Fairlane	67.50	B
64	C30Z-8005-C	Radiator Assy.—4V 1.95" core thickness 20¼" core width—Fairlane	67.50	B
65	C3DZ-8146-B	Fan Shroud—Mustang 4V	8.55	P
65	C50Z-8146-A	Fan Shroud—Fairlane	9.80	P
63-64	C20Z-8147-B	Fan Shroud R.H.—Fairlane	6.25	C
63-64	C20Z-8148-B	Fan Shroud L.H.—Fairlane	6.25	C
65	C3DZ-8149-B	Fan Shroud to Support Bracket—Mustang	.70	C
63-64	C30Z-8501-B	Water Pump Assy.—Fairlane 4V	15.85	C
65	C50Z-8501-A	Water Pump Assy.—Fairlane	15.85	C
65	C30Z-8501-B	Water Pump Assy.—Mustang W/Generator	15.85	C
65	C50Z-8501-A	Water Pump Assy.—Mustang W/Alternator	15.85	C
63	C30Z-8512-A	Water Pump Impeller—Fairlane—For C30Z-8501-A Pump	3.00	C
64-65	C40Z-8512-A	Water Pump Impeller—Fairlane & Mustang—For C30Z-8501-B & C50Z-8501-A Pumps	3.00	C
65	C20Z-8546-D	Pulley To Fan Spacer—4V W/Generator—Mustang	3.60	C
65	C30Z-8546-A	Pulley To Fan Spacer—4V W/Alternator—Mustang	1.95	C
65	C3DZ-8575-A	Water Thermostat W/Generator—Mustang—188°	3.00	A
65	C5DZ-8575-A	Water Thermostat W/Alternator—Mustang—192/195°	3.00	A
63	C20Z-8591-B	Water Pump Repair Kit—Fairlane—For C30Z-8501-A Pump—(Substitute C30Z-8512-A for C20Z-8512-A)	6.40	A
63-65	C30Z-8600-C	4 Blade Fan Assy.—Fairlane & Mustang	10.65	C
63-64	C30Z-8620-E	Fan Belt—Fairlane	2.70	C
65	C50Z-8620-A	Fan Belt—Fairlane		
65	C30Z-8620-E	Fan Belt—Mustang W/Generator	2.70	C
65	C50Z-8620-A	Fan Belt—Mustang W/Alternator	2.50	B
GENERATOR, STARTER, DISTRIBUTOR				
63-65	C30Z-10130-B	Generator Pulley—4V—Fairlane & Mustang	10.90	C
63-64	C20Z-11002-A	Starter Assy.—Fairlane	45.25	A
65	C20Z-11002-A	Starter Assy.—Fairlane (Auto. Trans.) Mustang	45.25	A
65	C5TZ-11002-A	Starter Assy.—Fairlane S/T	45.45	A
63-65	C50Z-12127-E	Distributor Assy.—4V—‡C50F-12127-E C30F-12127-D, C30F-12127-F (Fairlane)	41.50	C
65	C50Z-12127-E	Distributor Assy.—8V—‡C50F-12127-E C30F-12127-D, C30F-12127-F (Mustang)	41.50	C
65	C5ZZ-12127-D	Distributor Assy.—4V—‡C4ZF-12127-D (Mustang)—Replaced by C50Z-12127-E	41.50	C
63-65	C0AF-12152-A	Distributor Breaker Plate Assy.—(Fairlane)—4V	2.45	B
65	C0AF-12152-A	Distributor Breaker Plate Assy.—(Mustang)—4V	2.45	B

‡Identification Number Stamped on Distributor Housing.



FORD 289 HIGH PERFORMANCE ENGINE GENERAL PARTS LIST (CONTINUED)

Year	Part Number	Description	Mfrs. Sugg. Retail Price	Class	Year	Part Number	Description	Mfrs. Sugg. Retail Price	Class
63-65	FDS-12171-A	Distributor Breaker & Contact Point Set Assy.—(Fairlane)—4V	2.95	A	65	B8QH-12298-A	Ignition Coil To Distributor High Tension Wiring Assy.—Steel Core—Mustang—4V—From 8-20-64	.83	A
65	FDS-12171-A	Distributor Breaker & Contact Point Set Assy.—(Mustang)—4V	2.95	A	63-64	7RA-12300-C	Distributor Condenser Assy.—(Fairlane)—4V—Use with C30Z-12127-D	.93	A
63-64	C2TZ-12188-A	Distributor Weight Assy.—(Fairlane)—4V—Use with C30Z-12127-D	1.40	A	65	B9AF-12300-A	Distributor Condenser Assy.—(Fairlane)—4V—Use C50Z-12127-E	.93	A
65	C5AZ-12188-A	Distributor Weight Assy.—(Fairlane)—4V—Use with C50Z-12127-E	.87	A	65	7RA-12300-C	Distributor Condenser Assy.—(Mustang)—4V—Use with C30Z-12127-D	.93	A
65	C2TZ-12188-A	Distributor Weight Assy.—(Mustang)—4V—Use with C30Z-12127-D	1.40	A	65	B9AF-12300-A	Distributor Condenser Assy.—(Mustang)—4V—Use with C50Z-12127-E	.93	A
65	C5AZ-12188-A	Distributor Weight Assy.—(Mustang)—4V—Use with C50Z-12127-E	.87	A	SPEEDOMETER				
63-64	B8QH-12192-C	Distributor Weight Spring—Primary—(Fairlane)—4V—Use with C30Z-12127-D	.18	B	65	B7C-17285-A	Speedometer Driving Gear—Fairlane—F/4/S—6 teeth	2.75	A
65	C5AZ-12192-D	Distributor Weight Spring—Primary—(Fairlane)—4V—Use with C50Z-12127-E	.35	C	65	C30Z-17285-A	Speedometer Driving Gear—Fairlane—W/4/S—6 teeth	4.40	C
65	B8QH-12192-C	Distributor Weight Spring—Primary—(Mustang)—4V—Use with C30Z-12127-D	.18	B	65	C5ZZ-17285-A	Speedometer Driving Gear—Mustang—F/4/S—6 teeth	1.00	C
65	C5AZ-12192-D	Distributor Weight Spring—Primary—(Mustang)—4V—Use with C50Z-12127-E	.35	C	65	C0DD-17271-C	Driven Gear Assy.—Fairlane—3.89 Axle Ratio—6.95x14 tires—19 teeth—4/S/T	.95	A
63-64	C30Z-12192-A	Distributor Weight Spring—Secondary—(Fairlane)—4V—Use with C30Z-12127-D	.35	C	65	C0DD-17271-B	Driven Gear Assy.—Fairlane—3.89 Axle Ratio—7.35x14 tires—18 teeth—4/S/T	.95	A
65	C5AZ-12192-C	Distributor Weight Spring—Secondary—(Fairlane)—4V—Use with C50Z-12127-E	.35	C	65	C4DZ-17271-A	Driven Gear Assy.—Mustang—3.89 Axle Ratio—6.50x14, 6.95x14 tires—19 teeth—4/S/T	.95	C
65	C30Z-12192-A	Distributor Weight Spring—Secondary—(Mustang)—4V—Use with C30Z-12127-D	.35	C	65	C0DD-17271-A	Driven Gear Assy.—Fairlane—3.50 Axle Ratio—7.35x14 tires—16 teeth—4/S/T	.95	A
65	C5AZ-12192-C	Distributor Weight Spring—Secondary—(Mustang)—4V—Use with C50Z-12127-E	.35	C	65	C1DD-17271-A	Driven Gear Assy.—Fairlane—4.11 Axle Ratio—6.95x14 tires—20 teeth—4/S/T	.95	A
63-64	C3AZ-12210-A	Distributor Cam Assy.—(Fairlane)—4V—Use with C30Z-12127-D	6.00	C	65	C3DZ-17271-B	Driven Gear Assy.—Fairlane—3.50 Axle Ratio—6.95x14 tires—17 teeth—4/S/T	.95	A
65	C5AZ-12210-A	Distributor Cam Assy.—(Fairlane)—4V—Use with C50Z-12127-E	6.00	C	65	C0DD-17271-C	Driven Gear Assy.—Fairlane—4.11 Axle Ratio—7.35x14 tires—19 teeth—4/S/T	.95	A
65	C3AZ-12210-A	Distributor Cam Assy.—(Mustang)—4V—Use with C30Z-12127-D	6.00	C	65	C2DZ-17271-H	Driven Gear Assy.—Mustang—4.11 Axle Ratio—6.50x14, 6.95x14 tires—20 teeth—4/S/T	.95	C
65	C5AZ-12210-A	Distributor Cam Assy.—(Mustang)—4V—Use with C50Z-12127-E	6.00	C	65	C2DZ-17271-G	Driven Gear Assy.—Mustang—3.50 Axle Ratio—6.95x14 tires—17 teeth—4/S/T	.95	B
63-65	C0AF-12216-B	Distributor Primary Terminal Wire Assy.—(Fairlane)—4V	.45	C	65	C4OZ-17271-A	Driven Gear Assy.—Fairlane—3.89 Axle Ratio—6.95x14, 7.35x14 tires—21 teeth—auto. trans.	.95	C
65	C0AF-12216-B	Distributor Primary Terminal Wire Assy.—(Mustang)—4V	.45	C	65	C1DD-17271-A	Driven Gear Assy.—Fairlane—3.50 Axle Ratio—6.95x14 tires—20 teeth—auto. trans.	.95	A
63	C3AZ-12259-F	Spark Plug Wire Set—Steel Core—(Fairlane)—4V	9.00	A	65	C0DD-17271-C	Driven Gear Assy.—Fairlane—3.50 Axle Ratio—7.35x14 tires—19 teeth—auto. trans.	.95	A
64	C4OZ-12259-B	Spark Plug Wire Set—Steel Core—(Fairlane)—4V	10.00	A	SHOCK ABSORBERS				
65	C30Z-12259-H	Spark Plug Wire Set—Linen Core—(Fairlane, Mustang)—4V	7.50	A	65	C5ZZ-18A114-A	Rear Shock Absorbers Mounting Member Reinforcement—Mustang	3.20	C
65	C5ZZ-12259-A	Spark Plug Wire Set—Steel Core—(Fairlane, Mustang)—4V	10.00	A	65	C5ZZ-18124-C	Front Shock Absorber Kit—Mustang	9.80	C
65	C3AZ-12298-C	Ignition Coil To Distributor High Tension Wiring Assy.—Linen Core—(Fairlane, Mustang)—4V	.83	A	65	C5ZZ-18125-B	Rear Shock Absorber Kit—Mustang	9.80	A
65	C5ZZ-12298-A	Ignition Coil To Distributor High Tension Wiring Assy. Wire Core—(Mustang)—4V Before 8-20-64	.83	C	63-65	C30Z-18124-B	Front Shock Absorber Kit—Fairlane H/D	9.80	A
65	B8QH-12298-A	Ignition Coil To Distributor High Tension Wiring Assy.—Steel Core—(Fairlane)—4V	.83	A	63-65	C30Z-18125-D	Rear Shock Absorber Kit—Fairlane H/D	9.80	B

COMPETITIVE EVENT COMPONENTS—SPECIAL ORDER PARTS LISTING

1963 THROUGH 1965 427 C.I.D. 4V AND 8V COMPETITION ENGINES

ALL ITEMS NOT LISTED ARE STANDARD APPLICATION

Part Number	Description	1963/64 4V High Riser	1963/64 8V High Riser	1964 4V 7000	1964 8V 7000	1965 4V Low Profile	Mfrs. Sugg. Retail Price
C4AE-6007-H 361-A2	Engine Assy (Auto. Trans.) 8V		X				\$1327.00
C4AE-6007-H 361-A3	Engine Assy (Std. Trans.) 8V		X				1327.00
C5AE-6007-H 361-J2	Engine Assy (Std. Trans.) 4V Low-Profile "Wedge" Type					X	1327.00
C5AE-6009-K	Cylinder Assy					X	797.00
C4AE-6010-J	Block Assy	X	X	X	X		209.15
C5AE-6010-S	Block Assy					X	327.85
C4AE-6049-F	Cylinder Head	X	X	X	X		117.00
C5AE-6049-G	Cylinder Head					X	117.00
C3AE-6051-BS	Head Gasket—Stainless Steel—R.H.	X	X	X	X	X	3.25
C4AE-6051-BS	Head Gasket—Stainless Steel—L.H.	X	X	X	X	X	3.25
C3AE-6110-BJ	Piston		X		X		16.00
C5AE-6110-AU	Piston	X		X		X	16.00
C4AE-6135-A	Piston Pin					X	1.05
C3AE-6150-C	Compression Ring Upper		X		X		1.35
C4AE-6150-A	Compression Ring Upper	X		X		X	1.35
C3AE-6152-C	Compression Ring Lower		X		X		.64
C4AE-6152-A	Compression Ring Lower	X		X		X	.64
C3AE-6159-A	Segment—Oil Control		X		X		.64
C4AE-6159-B	Segment—Oil Control	X		X		X	.64
C3AE-6161-C	Expander Ring		X		X		.64
C4AE-6161-B	Expander Ring	X		X		X	.64
C4AE-6200-D	Connecting Rod	X	X	X	X	X	10.55
C4AE-6211-A	Bearing—Connecting Rod	X	X	X	X	X	1.45
C4AE-6214-G	Bolt—Connecting Rod	X	X				.52
C4AE-6214-J	Bolt—Connecting Rod			X	X	X	.52
C4AE-6250-B	Camshaft			X	X		48.30
C5AE-6250-D	Camshaft					X	48.30
C5AE-6262-D	Bearing Camshaft—Center					X	2.45
C5AE-6263-A	Bearing Camshaft—Rear					X	2.45
C5AE-6267-A	Bearing Camshaft—Front-Inter.					X	2.45
C5AE-6270-A	Bearing Camshaft—Rear-Inter.					X	2.45
C4AE-6300-C	Crankshaft Assy (Steel)			X	X	X	138.00
C4AE-6333-A	Crankshaft Bearing (Red)	X	X	X	X	X	2.25
C4AE-6333-B	Crankshaft Bearing (Blue)	X	X	X	X	X	2.25
C4AE-6333-G	Crankshaft Bearing (Thin-Wall)	X	X	X	X	X	2.25
C4AE-6337-T	Crankshaft Bearing (Red)	X	X	X	X	X	3.55
C4AE-6337-U	Crankshaft Bearing (Blue)	X	X	X	X	X	3.55
C4AE-6337-AB	Crankshaft Bearing (Thin-Wall)	X	X	X	X	X	3.55
C4AE-6A338-A	Crankshaft Bearing (Thin-Wall)	X	X	X	X	X	2.25
C4AE-6A339-C	Crankshaft Bearing (Thin-Wall)	X	X	X	X	X	3.55
C4AE-6500-E	Tappet	X	X	X	X	X	1.50
C3AE-6505-N	Exhaust Valve	X	X				9.00
C4AE-6505-E	Exhaust Valve			X	X	X	10.75
C3AE-6507-J	Intake Valve	X	X				3.05
C4AE-6507-S	Intake Valve			X	X	X	3.25
C4AE-6524-B	Oil Baffle	X	X	X	X		2.55
C5AE-6524-A	Oil Baffle					X	2.55
C3AE-6A527-A	Bolt—Rocker Arm Stand	X	X	X	X		.66
C3AE-6531-A	Rocker Arm Stand	X	X	X	X		4.75
C5AE-6531-A	Rocker Arm Stand					X	4.75
C3AE-6563-B	Rocker Arm Shaft	X	X	X	X	X	6.10
C3AE-6571-D	Valve Stem Seal	X	X	X	X	X	.42
C4AE-6600-E	Oil Pump					X	16.55
C4AE-6622-D	Pick up Tube	X	X	X	X	X	6.85
C5AE-6622-C	Pick Up Tube					X	6.85
C4AE-6675-L	Oil Pan	X	X	X	X	X	55.70

COMPETITIVE EVENT COMPONENTS—SPECIAL ORDER PARTS LISTING—Cont'd

Part Number	Description	1963/64 4V High Riser	1963/64 8V High Riser	1964 4V 7000	1964 8V 7000	1965 4V Low Profile	Mfrs. Sugg. Retail Price
C4AE-6714-A	Oil Filter	X	X	X	X	X	\$ 42.00
C3AE-6750-L	Dip Stick	X	X	X	X		2.45
C4AE-6758-C	Tube—Crankcase Vent	X	X	X	X	X	4.45
C4AE-6A829-A	Tab—Pick Up Tube Mounting	X	X	X	X	X	1.05
C4AE-6A829-B	Tab—Pick Up Tube Mounting	X	X	X	X	X	1.05
C5AA-7550-G	Clutch Disc—Aluminum Back	X	X	X	X	X	53.80
C4AE-8620-J	Fan Belt	X	X	X	X	X	3.25
C4AE-9424-F	Intake Manifold		X		X		159.65
C4AE-9424-G	Intake Manifold	X		X			149.30
C4AE-9A424-A	Seal—Intake Manifold—Rear	X	X	X	X	X	.25
C4AE-9A425-A	Seal—Intake Manifold—Front	X	X	X	X	X	.25
C5AE-9424-K	Intake Manifold					X	149.30
C3AE-9439-A	Gasket—Intake Manifold	X	X	X	X		1.25
C5AE-9439-A	Gasket—Intake Manifold					X	1.25
C4AE-9447-C	Gasket—Carburetor to Manifold	X		X		X	.33
C4AF-9510-DA	Carburetor	X		X			79.45
C4AF-9510-CU	Carburetor—Primary		X		X		79.45
C4AF-9510-CV	Carburetor—Secondary		X		X		79.45
C5AF-9510-BE	Carburetor					X	79.45
C4AF-9600-BD	Air Cleaner	X		X			32.40
MT-9600-A	Air Box		X		X		25.85
C5AF-9600-AN	Air Cleaner					X	32.40
C4AF-9601-C	Air Cleaner Element	X		X		X	6.90
378519-S	Dowel—Connecting Rod			X	X	X	.17
S-4116	Gasket—Exhaust Header	X	X	X	X		.25

Special order parts listing continued on next page.

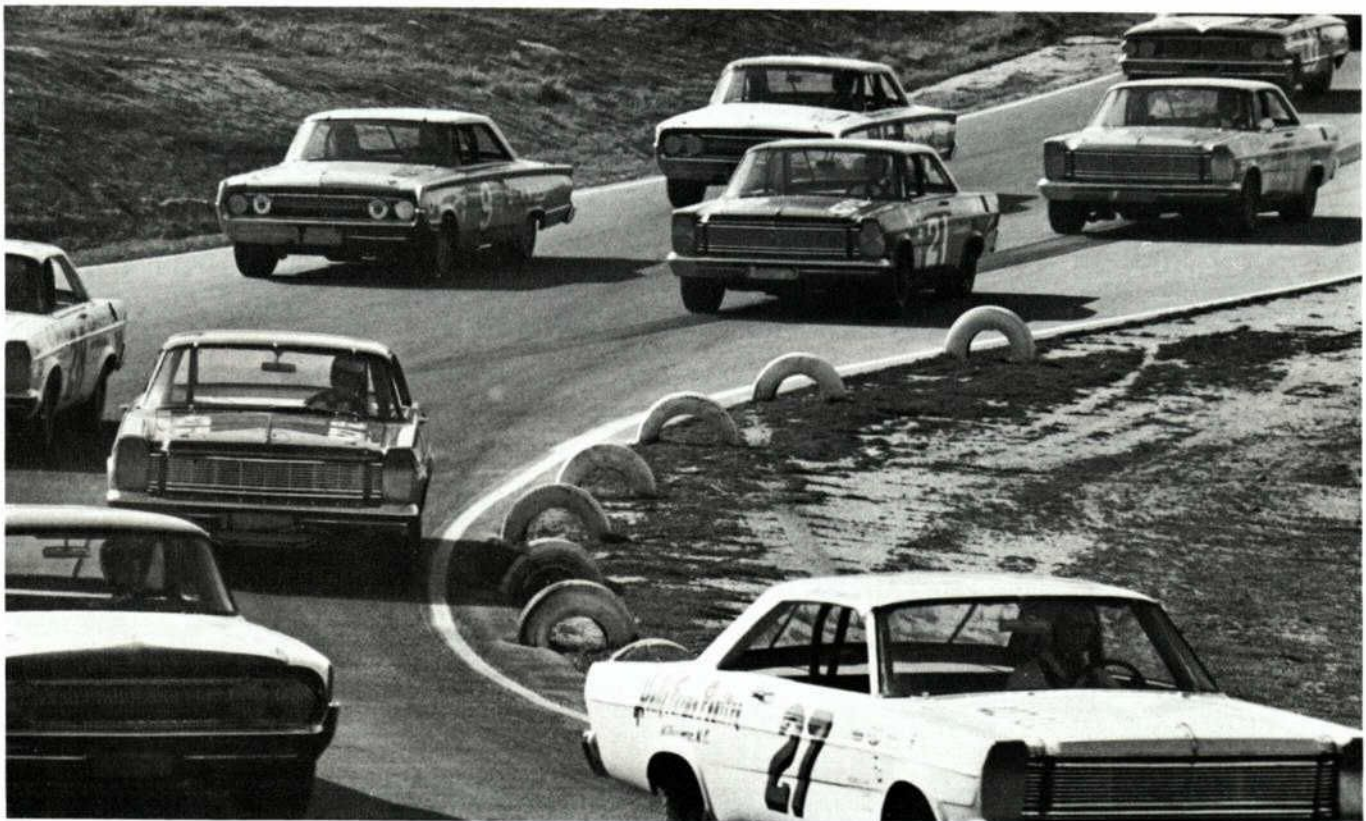

1964 FORD AND FAIRLANE DRAGSTER REAR AXLE SPECIAL PARTS LISTING

ALL ITEMS NOT SHOWN ARE STANDARD 427 GALAXIE REAR AXLE PARTS

Part Number	Description	Ford Dragster	Fairlane Dragster	MFRS. Sugg. Retail Price
C3AW-4010-F	Housing—Rear Axle	X	X	\$59.35
C3OW-4010-J	Housing—Rear Axle		X	59.35
C2AW-4017-A	Case Assy—Carrier		X	34.30
C4AW-4234-A	Axle Shaft—R.H. (31 Spline)	X		55.00
C4OW-4234-A	Axle Shaft—R.H. (31 Spline)		X	55.00
C4AW-4602-C	Driveshaft (Auto. Trans.)	X		50.00
C4OA-4602-B	Driveshaft (Auto. Trans.)		X	50.00
C4OA-4602-C	Driveshaft (Std. Trans.)		X	50.00
C4AW-4630-A	Cone & Roller—Pinion Gear	X	X	4.48
C4AW-4725-A	Axle Shaft—L.H. (31 Spline)	X		55.00
C4OW-4725-A	Axle Shaft—L.H. (31 Spline)		X	55.00
WAB-44205-A	Seat—Differential Pinion Shaft	X	X	3.55
WAB-44207-A	Shaft—Differential Pinion	X	X	.98

1964 FORD AND FAIRLANE SPECIAL BODY PARTS LISTING

Part Number	Description	Ford	Fairlane	MFRS. Sugg. Retail Price
GF-3-X	Cooler Line	X		\$43.10
GF-4-X	Cooler Line	X		43.10
64G-WMAT	Air Tube (6" Dia.—10" Length)		X	20.70
ATL-64-G	Air Tube (L.H.)	X		25.85
ATR-64-G	Air Tube (R.H.)	X		25.85
B-64-FF	Front Bumper (Fiberglass)		X	30.70
H-64-FF	Hood (Fiberglass)		X	86.20
H-64-G	Hood (Fiberglass)	X		86.20
LH-64-FF	Fender—L.H. (Fiberglass)		X	43.10
RH-64-FF	Fender—R.H. (Fiberglass)		X	43.10

1964 FORD AND FAIRLANE DRAGSTER TRANSMISSION—SPECIAL PARTS LISTING

Part Number	Description	Galaxie 4-Speed	Fairlane 4-Speed	Galaxie Automatic	MFRS. Sugg. Retail Price
T-10K-16B	Main Drive Gear		X		\$ 46.50
SK-4516-QY8	Countershaft Gear	X			109.70
SK-4516-QY11	Third Speed Gear	X			69.60
SK-4516-RB8A	Countershaft Gear		X		109.70
SK-4516-RB11A	Third Speed Gear		X		69.60
SK-4516-RB31A	Second Speed Gear		X		62.40
C4AP-7000-U	Transmission Assy (Automatic)			X	646.55
O4AR-7003-R	Transmission Assy (4 Speed)	X			398.00
C3AZ-7006-DSO	Transmission Case (Aluminum)	X	X		58.65
C3AZ-7A039-DSO	Extension Housing (Aluminum)	X	X		59.25
C4AP-7C053-B	Governor Assy			X	12.10
C4AP-7A100-F	Main Control			X	75.00
C4AP-7A256-D	Lever Assy			X	5.85
C4AP-7902-E	Convertor Assy			X	146.55
XA-560732	Transmission Assy (4 Speed)		X		398.00



Make Your Ford
Dealer Your
**"PERFORMANCE
HEADQUARTERS"**

... equipped to help
you with all your
high performance
requirements

WITH MODERN DIAGNOSIS EQUIPMENT

- Performance testing in minutes
- Fast, scientific tune-ups
- Malfunctions can be pinpointed quickly, so they can be remedied without return trips

**WITH A WIDE RANGE
OF PERFORMANCE EQUIPMENT**

- Highest quality, manufactured to rigid Ford specifications
- A complete selection, from replacement parts to special equipment for maximum performance
- Stock readily available through Ford Motor Company's vast supply system

